

# SPECIFICATION FOR AMOLED MODULE

**MODULE NO: YB-OG10801920S01A-N-A0**

**Doc.Version:00**

Customer Approval:

|                                 |                                 |
|---------------------------------|---------------------------------|
| <input type="checkbox"/> Accept | <input type="checkbox"/> Reject |
|---------------------------------|---------------------------------|

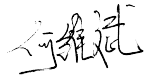
| YEEBO    | NAME                | SIGNATURE                                                                            | DATE      |
|----------|---------------------|--------------------------------------------------------------------------------------|-----------|
| Prepare  | Mechanical Engineer |  | 2024/7/12 |
| Check    | Electronic Engineer |                                                                                      |           |
| Verify   |                     |                                                                                      |           |
| Approval |                     |                                                                                      |           |

■APPROVAL FOR SPECIFICATIONS ONLY

APPROVAL FOR SPECIFICATIONS AND SAMPLE

WIMRD005-02-D



## 2. Table of Contents

| NO | CONTENTS                         | PAGE |
|----|----------------------------------|------|
| 1  | Revision History                 | 1    |
| 2  | Table of Contents                | 2    |
| 3  | Module Numbering System          | 3    |
| 4  | General Specification            | 4    |
| 5  | Dimensional Outline              | 5    |
| 6  | Electrical Characteristics       | 6    |
| 7  | Optical Characteristics          | 14   |
| 8  | Interface Pin Assignment         | 15   |
| 9  | Block Diagram                    | 17   |
| 10 | Environmental / Reliability Test | 18   |
| 11 | Quality Level                    | 19   |

### 3. Module Numbering System (example)

**YB- T G 240320 S 01 D -T - A0**

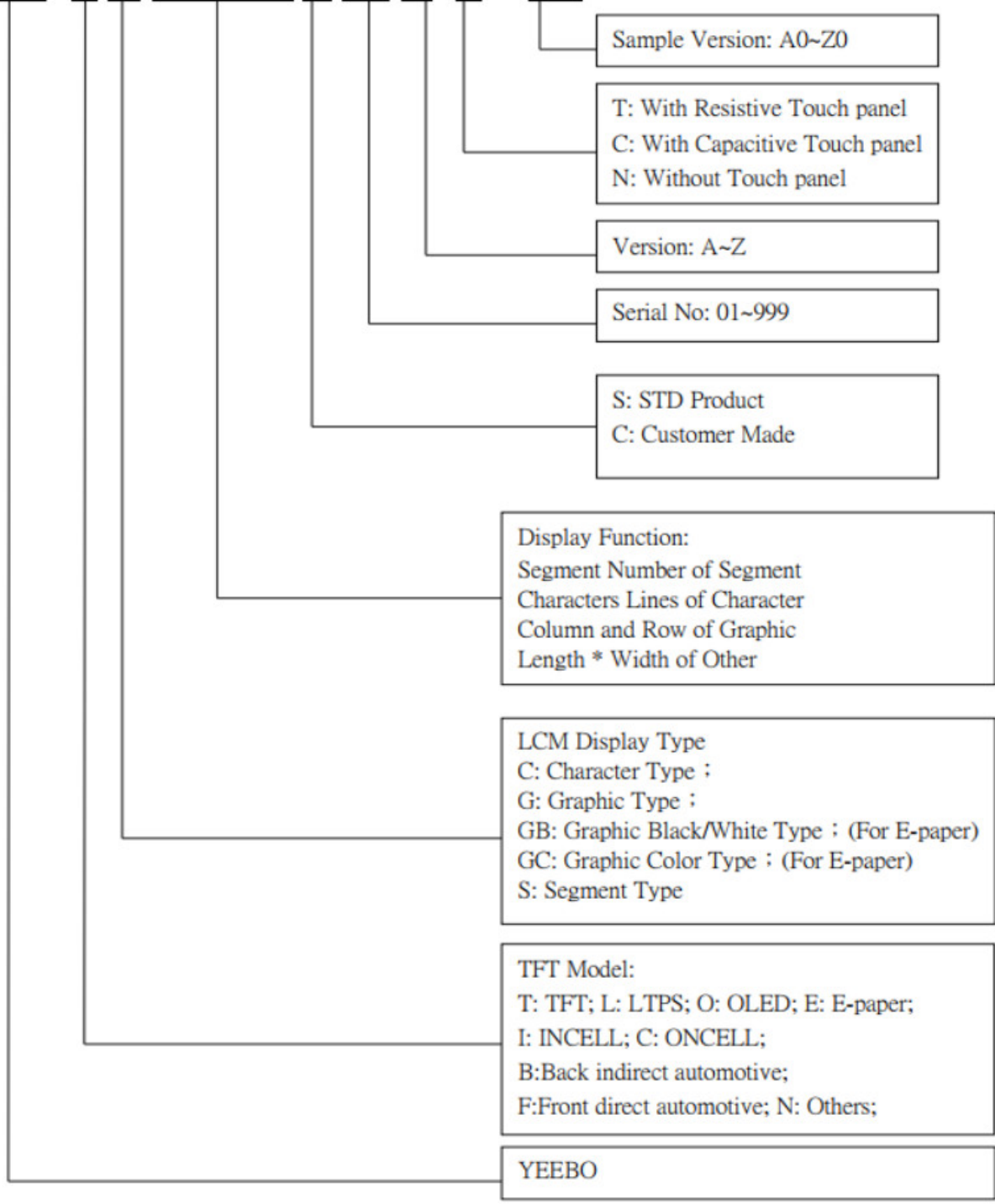

#### 4. General Specification

| Feature                           |                                          | Spec                          | Remark |
|-----------------------------------|------------------------------------------|-------------------------------|--------|
| <b>Display Spec</b>               | Screen Size (inch)                       | 5.48                          |        |
|                                   | Display Mode                             | AMOLED                        |        |
|                                   | Resolution(dot)                          | 1080(W)×1920(H)               |        |
|                                   | Active Area(mm)                          | 68.256(W)×121.344 (H)         |        |
|                                   | Pixel Pitch (um)                         | 94.8 (W)×63.2(H)              |        |
|                                   | Technology Type                          | LTPS                          |        |
|                                   | Color Depth                              | 16.7M                         |        |
|                                   | Interface                                | MIPI 4LANE                    |        |
| <b>Mechanical Characteristics</b> | Polarizer Surface Treatment              | HC Coating                    |        |
|                                   | With TP/Without TP                       | With TP(on Cell)              |        |
|                                   | Module Outline Dimension(W x H x D) (mm) | 70.356(W)*127.344(H)*1.125(D) |        |
| <b>Electronic</b>                 | Driver IC(Type)                          | CH13721C                      |        |
|                                   | Touch IC(Type)                           | FT3519                        |        |
|                                   | Frame Rate                               | 60HZ                          |        |

Note 1: Requirements on Environmental Protection: RoHS 2.0.



## 6. Electrical Characteristics

### 6-1 Absolute Maximum Ratings

#### 6-1-1 Driving AMOLED Panel

Maximum Ratings (Voltage Referenced to VSS) VSS=0V, Ta=25°C

| Item                 | Symbol | MIN  | MAX  | Unit |
|----------------------|--------|------|------|------|
| Analog Power supply  | VCI    | 0    | +6.3 | V    |
| Logic Power supply   | VDDIO  | 0    | +6.3 | V    |
| Analog Power supply  | AVDD   | 0    | +8.4 | V    |
| Positive Power Input | ELVDD  | -    | +5.0 | V    |
| Negative Power Input | ELVSS  | -5.0 | -    | V    |

Not6.3e: Functional operation should satisfy the limits in the Electrical Characteristics tables or Pin Description section. If the module exceeds the absolute maximum ratings, permanent damage may occur. Besides, if the module is operated with the absolute maximum ratings for a long time, the reliability may also drop.

#### 6-2-3 TP Operating Conditions

| Item                               | Symbol    | MIN | MAX | Unit |
|------------------------------------|-----------|-----|-----|------|
| TP power supply Input              | TSP_AVDD  | 2.7 | 3.6 | V    |
| TP power supply for logic circuits | TSP_VDDIO | 1.7 | 3.6 | V    |

## 6-2 Operating Conditions

### 6-2-1 Driving AMOLED Panel

Ta=25°C

| Item                                    | Symbol     | MIN  | TYP        | MAX  | Unit       |   |
|-----------------------------------------|------------|------|------------|------|------------|---|
| Logic Power Supply                      | VDDIO      | 1.65 | 1.80       | 3.3  | V          |   |
| Analog Power Supply                     | VCI        | 2.5  | 3.0        | 3.60 | V          |   |
| Analog Power Supply                     | AVDD       | 6.4  | 6.7        | TBD  | V          |   |
| Default Positive Output Voltage         | ELVDD      |      | 4.60       |      | V          |   |
| Positive Output Voltage Total Variation |            |      | -          |      | %          |   |
| Default Negative Output Voltage         | ELVSS      |      | -3.00      |      | V          |   |
| Negative Output Voltage Total Variation |            |      | -          |      | %          |   |
| Input Signal Voltage                    | High Level | VIH  | 0.70*VDDIO | -    | VDDIO      | V |
|                                         | Low Level  | VIL  | 0.00       | -    | 0.30*VDDIO | V |
| Output Signal Voltage                   | High Level | VOH  | 0.80*VDDIO | -    | VDDIO      | V |
|                                         | Low Level  | VOL  | 0.00       | -    | 0.20*VDDIO | V |

Note: The current and power consumption were tested under White pattern, 25°C

### 6-2-2 TP Operating Conditions

| Item                               | Symbol    | MIN | TYP          | MAX | Unit |
|------------------------------------|-----------|-----|--------------|-----|------|
| TP power supply Input              | TSP_AVDD  | 2.8 | 2.8/3.0/3.3  | 3.6 | V    |
| TP power supply for logic circuits | TSP_VDDIO | 1.7 | 1.8/TSP_AVDD | 3.6 | V    |

### 6-2-3 General Specifications

| NO | ITEM                            | SPEC                         | REMARK |
|----|---------------------------------|------------------------------|--------|
| 1  | Accuracy @D7mm<br>Finger(mm)    | center≤1.0mm<br>border≤1.5mm |        |
| 2  | Linearity @ D7mm<br>Finger(mm)  | center≤1.0mm<br>border≤1.5mm |        |
| 3  | Jitter @D7mm Finger(mm)         | All≤1.0mm                    |        |
| 4  | Sensitivity @D7mm<br>Finger(mm) | w/o line broken              |        |
| 5  | Report rate                     | Typ: 120Hz<br>Max: 240Hz     |        |
| 6  | Touch Point                     | Max 10 Fingers               |        |

## 6-2-4 Touch Design

| Item         |                  | Description | Notes |
|--------------|------------------|-------------|-------|
| Touch Design | Sensor structure | Oncell      |       |

## 6-3 AC Characteristics

### 6-3-1 MIPI Interface Characteristics

#### HS Data Transmission Burst

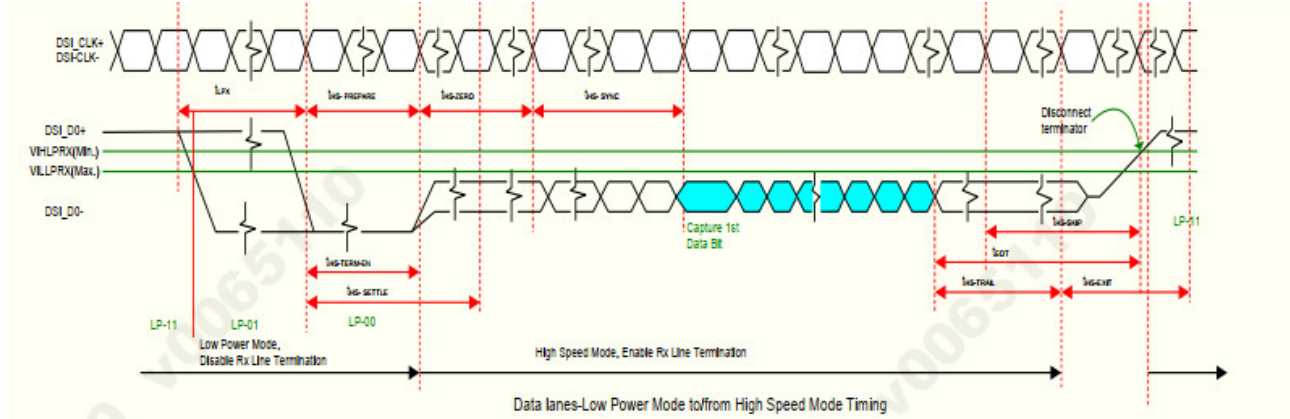

#### HS clock transmission

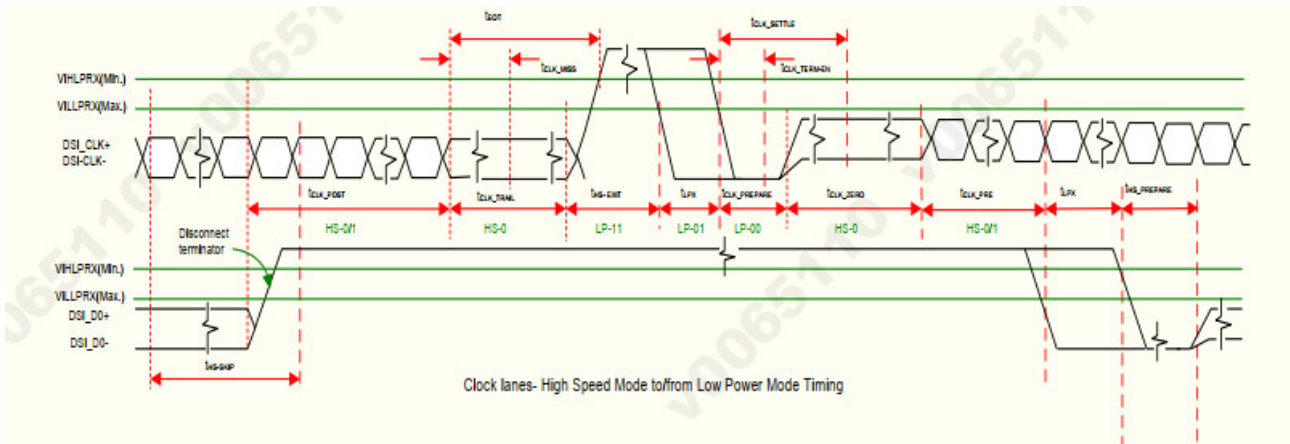

Timing Parameters:

| Signal                                               | Symbol                           | Parameter                                                                                                            | Min.              | Typ. | Max.             | Unit | Description |
|------------------------------------------------------|----------------------------------|----------------------------------------------------------------------------------------------------------------------|-------------------|------|------------------|------|-------------|
| <b>Low Power Mode to High Speed Mode Timing</b>      |                                  |                                                                                                                      |                   |      |                  |      |             |
| DSI-Dn+/-                                            | $t_{LPX}$                        | Length of any low power state period                                                                                 | 50                | -    | -                | ns   | Input       |
| DSI-Dn+/-                                            | $t_{HS-PREPARE}$                 | Time to drive LP-00 to prepare for HS transmission                                                                   | $40+4 \times UI$  | -    | $85+6 \times UI$ | ns   | Input       |
| DSI-Dn+/-                                            | $t_{HS-TERM-EN}$                 | Time to enable data receiver line termination measured from when Dn crosses $V_{ILMAX}$                              | -                 | -    | $35+4 \times UI$ | ns   | Input       |
| <b>High Speed Mode to Low Power Mode Timing</b>      |                                  |                                                                                                                      |                   |      |                  |      |             |
| DSI-Dn+/-                                            | $t_{HS-SKIP}$                    | Time-out at display module to ignore transition period of EoT                                                        | 40                | -    | $55+4 \times UI$ | ns   | Input       |
| DSI-Dn+/-                                            | $t_{HS-EXIT}$                    | Time to drive LP-11 after HS burst                                                                                   | 100               | -    | -                | ns   | Input       |
| DSI-Dn+/-                                            | $t_{HS-TRAIL}$                   | Time to drive flipped differential state after last payload data bit of a HS transmission burst                      | $60+4 \times UI$  | -    | -                | ns   | Input       |
| <b>High Speed Mode to/from Low Power Mode timing</b> |                                  |                                                                                                                      |                   |      |                  |      |             |
| DSI-CLK+/-                                           | $t_{CLK-POS}$                    | Time that the MPU shall continue sending HS clock after the last associated data lane has transition to LP mode      | $60+52 \times UI$ | -    | -                | ns   | Input       |
| DSI-CLK+/-                                           | $t_{CLK-TRAIL}$                  | Time to drive HS differential state after last payload clock bit of a HS transmission burst                          | 60                | -    | -                | ns   | Input       |
| DSI-CLK+/-                                           | $t_{HS-EXIT}$                    | Time to drive LP-11 after HS burst                                                                                   | 100               | -    | -                | ns   | Input       |
| DSI-CLK+/-                                           | $t_{CLK-PREPARE}$                | Time to drive LP-00 to prepare for HS transmission                                                                   | 38                | -    | 95               | ns   | Input       |
| DSI-CLK+/-                                           | $t_{CLK-TERM-EN}$                | Time-out at clock lane display module to enable HS transmission                                                      | -                 | -    | 38               | ns   | Input       |
| DSI-CLK+/-                                           | $t_{CLK-PREPARE} + t_{CLK-ZERO}$ | Minimum lead HS-0 drive period before starting clock                                                                 | 300               | -    | -                | ns   | Input       |
| DSI-CLK+/-                                           | $t_{CLK-PRE}$                    | Time that the HS clock shall be driven prior to any associated data lane beginning the transition from LP to HS mode | $8 \times UI$     | -    | -                | ns   | Input       |

Note 1: VDDIO/VDDAM/VDDR = 1.65~3.6V, VCI=2.5 to 3.6V VSSIO=DVSS=VSSA=VSSAM=VSSR =VSSB=0V, Ta=-30 to +85 °C.

Note 2: Dn=D0, D1, D2 and D3.

Bus Turnaround from MPU to display module

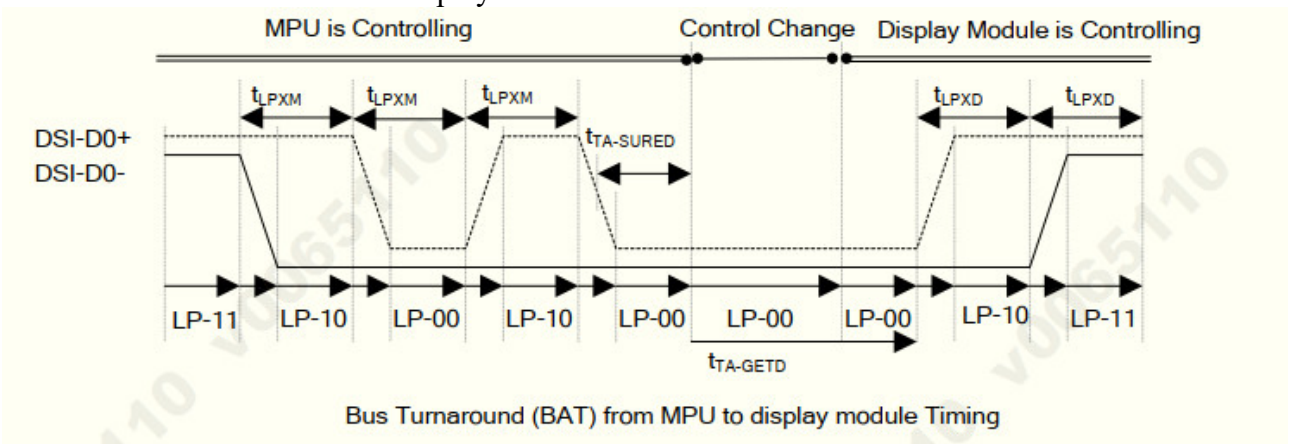

### Bus Turnaround from display module to MPU

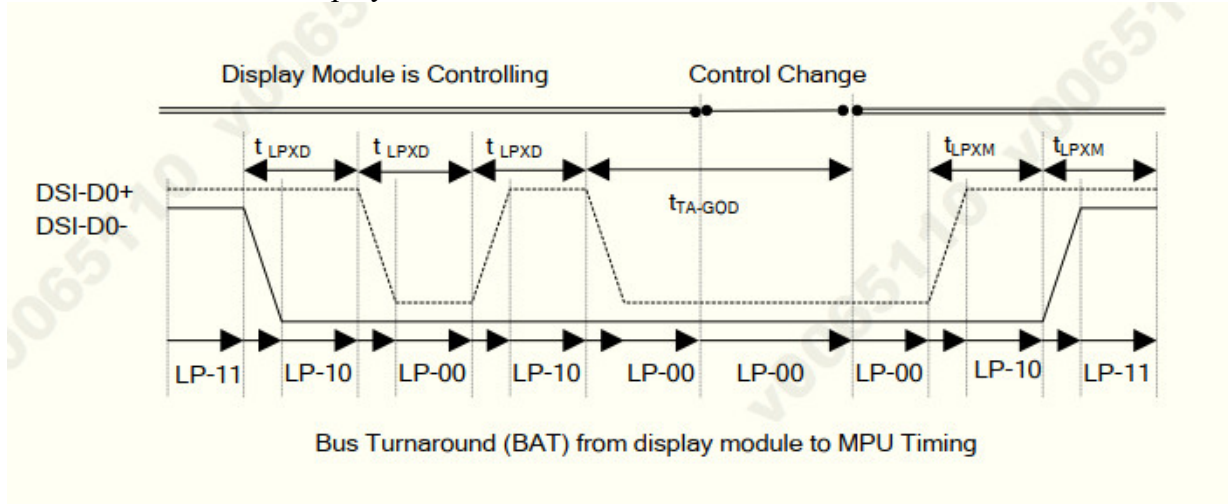

#### Timing Parameters:

| Signal    | Symbol         | Parameter                                                           | Min.                | Typ. | Max.                | Unit | Description |
|-----------|----------------|---------------------------------------------------------------------|---------------------|------|---------------------|------|-------------|
| DSI-D0+/- | $t_{LPXM}$     | Length of LP-00, LP-01, LP-10 or LP-11 periods MPU → Display Module | 50                  | -    | 75                  | ns   | Input       |
| DSI-D0+/- | $t_{LPXD}$     | Length of LP-00, LP-01, LP-10 or LP-11 periods Display Module → MPU | 50                  | -    | 75                  | ns   | Output      |
| DSI-D0+/- | $t_{TA-SURED}$ | Time-out before the MPU start driving                               | $t_{LPXD}$          | -    | $2 \times t_{LPXD}$ | ns   | Output      |
| DSI-D0+/- | $t_{TA-GETD}$  | Time to drive LP-00 by display module                               | $5 \times t_{LPXD}$ | -    | -                   | ns   | Input       |
| DSI-D0+/- | $t_{TA-GOD}$   | Time to drive LP-00 after turnaround request - MPU                  | $4 \times t_{LPXD}$ | -    | -                   | ns   | Output      |

Note 1: VDDIO/VDDAM/VDDR = 1.65~3.6V, VCI=2.5 to 3.6V, VSSIO=DVSS=VSSA=VSSAM=VSSR =VSSB=0V, Ta=-30 to +85 °C.

### 6-3-2 Display RESET Timing Characteristics

#### Reset input timing:

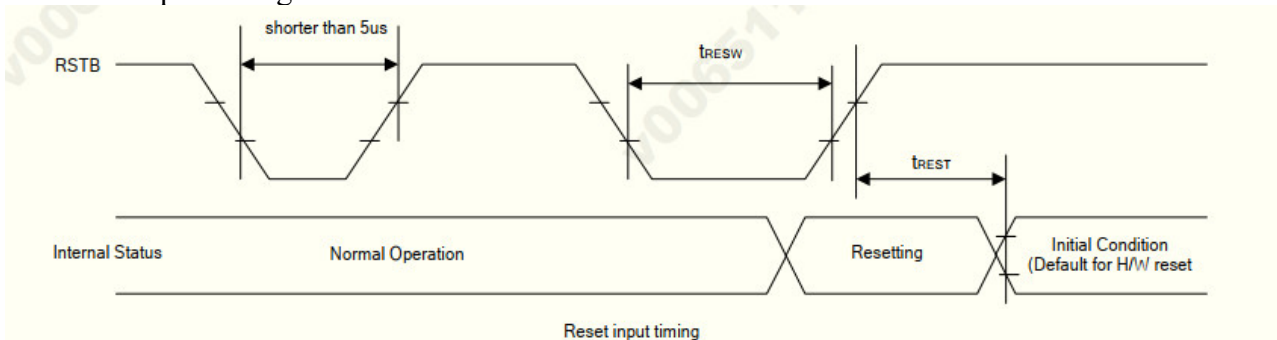

#### Timing Parameters

| Signal | Symbol     | Parameter                      | Min. | Typ. | Max. | Unit    | Description                              |
|--------|------------|--------------------------------|------|------|------|---------|------------------------------------------|
| RSTB   | $t_{RESW}$ | Reset "L" pulse width (Note 1) | 10   | -    | -    | $\mu s$ | -                                        |
|        | $t_{REST}$ | Reset complete time (Note 2)   | -    | -    | 5    | ms      | When reset applied during Sleep In Mode  |
|        |            |                                | -    | -    | 120  | ms      | When reset applied during Sleep Out Mode |

Note 1: Spike due to an electrostatic discharge on RSTB line does not cause irregular system Reset according to the table below.

| RSTB Pulse                       | Action         |
|----------------------------------|----------------|
| Shorter than 5 $\mu$ s           | Reset Rejected |
| Longer than 10 $\mu$ s           | Reset          |
| Between 5 $\mu$ s and 10 $\mu$ s | Reset Start    |

Note 2: During the Resetting period, the display will be blanked (The display is entering blanking sequence, which maximum time is 120 ms, when Reset Starts in Sleep Out –mode. The display remains the blank state in Sleep In–mode) and then return to Default condition for H/W Reset.

Note 3: During Reset Complete Time, values in OTP memory will be latched to internal register during this period. This loading is done every time when there is H/W Reset complete time ( $t_{REST}$ ) within 5ms after a rising edge of RSTB.

Note 4: Spike Rejection also applies during a valid Reset pulse as shown below.

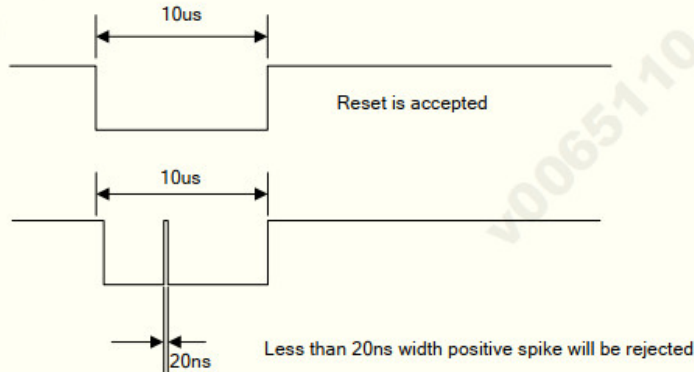

Note 5: It is necessary to wait 5msec after releasing RSTB before sending commands. Also Sleep Out command cannot be sent for 120msec.

### TE Timing Characteristics

Model1, The Tearing Effect Output line consists of V-Blanking information only.

Mode 1, the Tearing Effect Output signal consists of V-Blanking Information only:

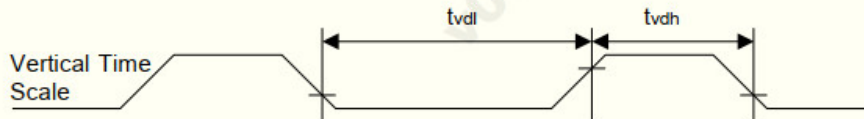

$T_{vdh}$  = The display panel is not updated from the Frame Memory

$T_{vdl}$  = The display panel is updated from the Frame Memory(except Invisible Line –see below)

Mode 2, the Tearing Effect Output signal consists of V-Blanking and H-Blanking Information, there is one Vsync and 1920 H-sync pulses per field.

## 6-4 Recommended Operating Sequence

### 6-4-1 Display Power on / off Sequence

#### Power On Sequence

The Power on sequence has been applied following Fig1, otherwise correct functionality is not guaranteed.

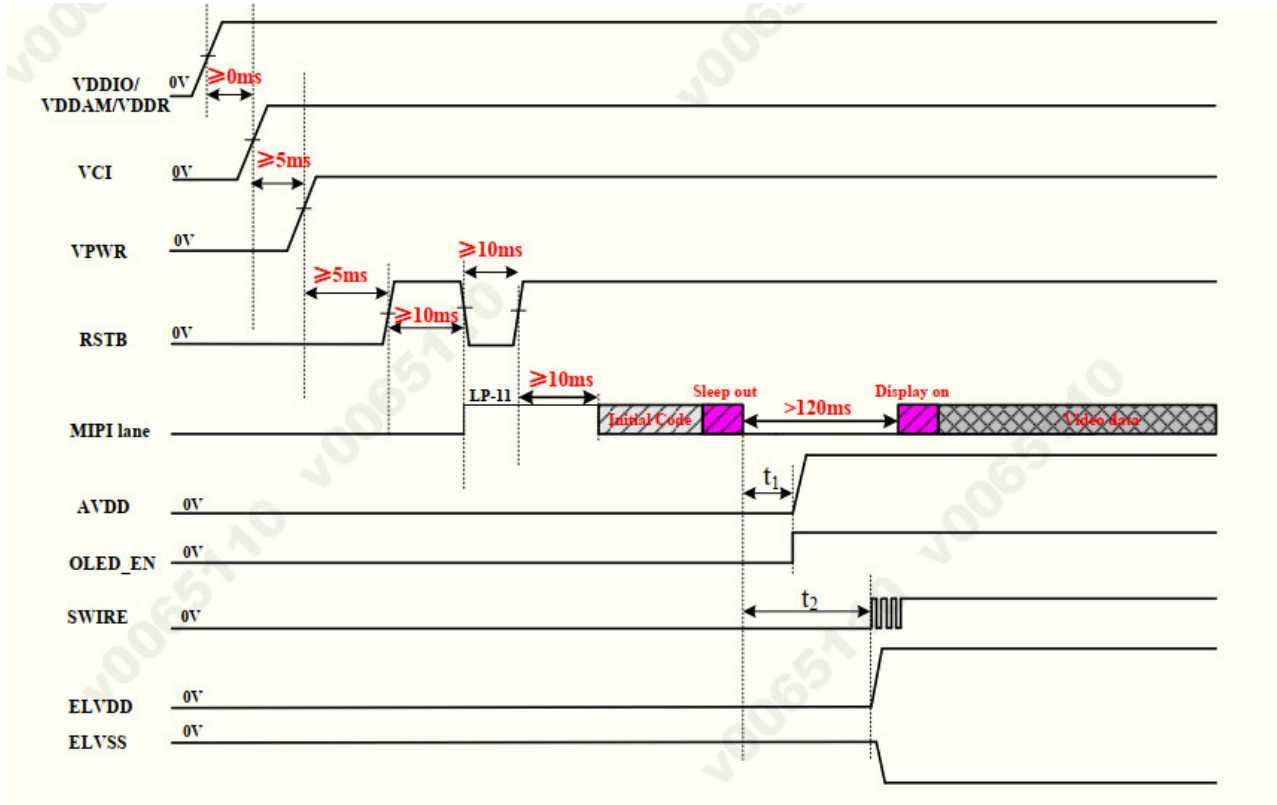

Fig 1 Power on sequence

Note1:  $t_1$  is AVDD set up time, is controlled by AVDD\_ONT[7:0];

Note2:  $t_2$  is ELVDD/ELVSS set up time, is controlled by SWIRE\_ONF[5:0];

Note3: VPWR is the power of Power IC for AVDD/ELVDD/ELVSS;

### 6-4-2 Power Off Sequence

The Power off sequence have been applied following Fig2, otherwise correct functionality is not guaranteed

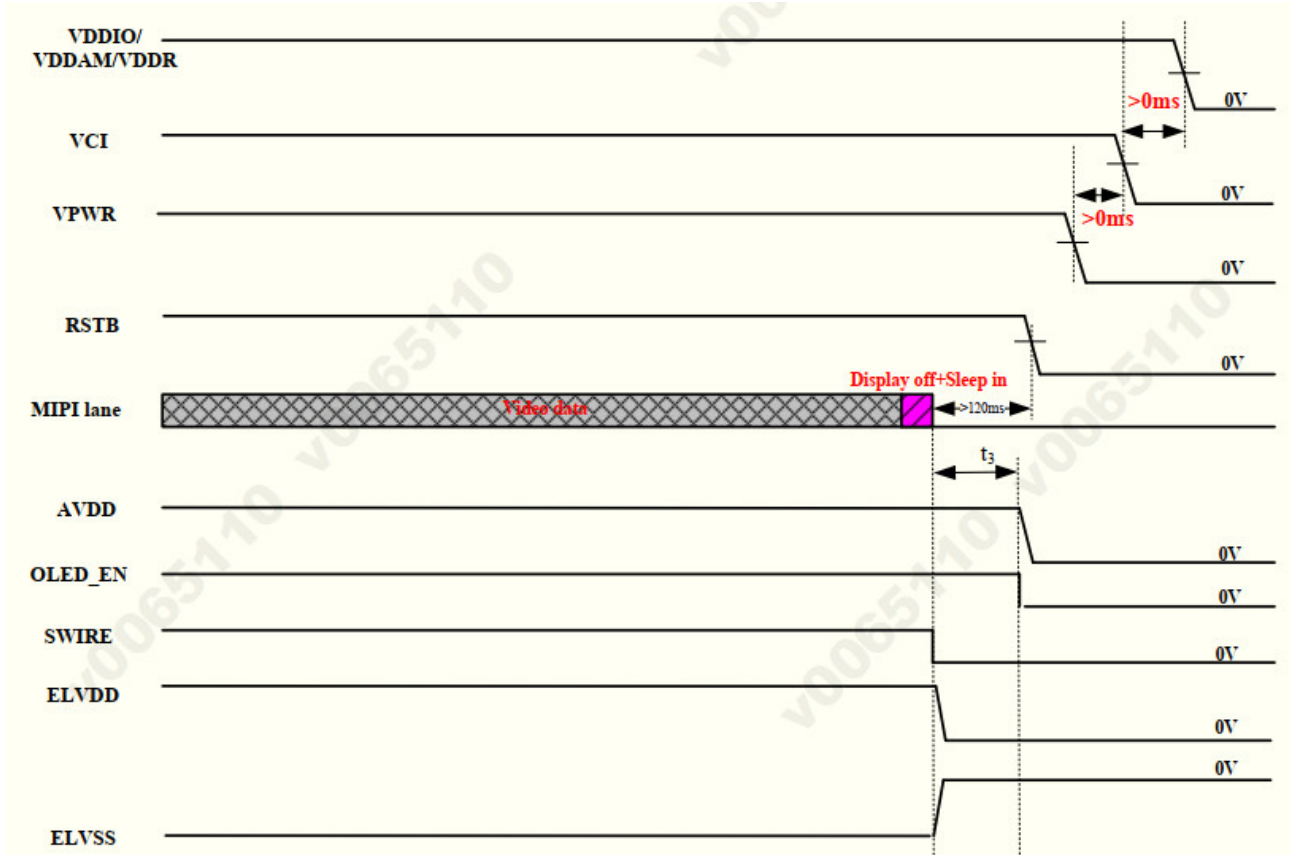

Fig 2 Power off sequence

Note1:  $t_3$  is Power off Delay time, is controlled by AVDD\_OFT[7:0];  
 Note2: VPWR is the power of Power IC for AVDD/ELVDD/ELVSS;

### 6-4-3 Brightness control

| Inst/Para | R/W | Address |       | Date Type | Description          |
|-----------|-----|---------|-------|-----------|----------------------|
|           |     | MIPI    | Other |           |                      |
| BRTCTRL   | W   | 51h     | 5100h | Hex       | Value form 0~255(FF) |

## 7. Optical Characteristics

| Item         | Symbol | Condition | Min     | Typ     | Max     | Unit              | Remark                                                                                      |
|--------------|--------|-----------|---------|---------|---------|-------------------|---------------------------------------------------------------------------------------------|
| Luminance    | L      |           | 280     | 350     | 420     | Cd/m <sup>2</sup> | Note1<br>Test Equipment:<br>CS2000A<br>The spec. After OTP<br>depend on customer t<br>uning |
| Chromaticity | white  | x         |         | (0.300) |         |                   |                                                                                             |
|              |        | y         |         | (0.315) |         |                   |                                                                                             |
|              | Red    | x         | (0.652) | (0.682) | (0.712) |                   |                                                                                             |
|              |        | y         | (0.285) | (0.315) | (0.345) |                   |                                                                                             |
|              | Green  | x         | (0.200) | (0.240) | (0.280) |                   |                                                                                             |
|              |        | y         | (0.676) | (0.716) | (0.756) |                   |                                                                                             |
|              | Blue   | x         | (0.108) | (0.138) | (0.168) |                   |                                                                                             |
|              |        | y         | (0.018) | (0.048) | (0.078) |                   |                                                                                             |

Test Conditions:

1. The ambient temperature is 25°C.
2. The test systems refer to Note1 and Note2.

Note 1: Definition of optical measurement system.

The optical characteristics should be measured in dark room. The optical properties are measured at the center point of the AMOLED screen. All input terminals AMOLED panel must be ground when measuring the center area of the panel.

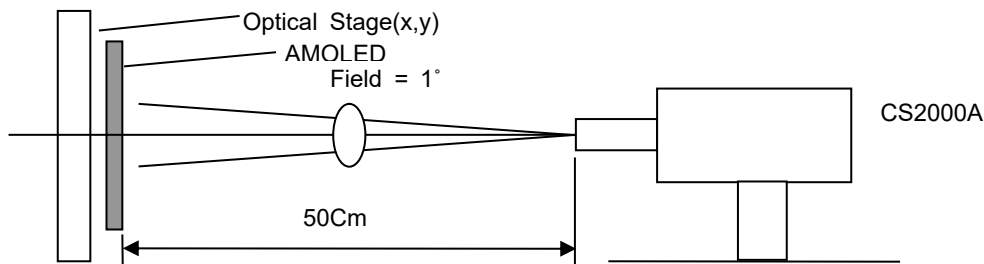

Note 2: Definition of color chromaticity (CIE1931)

Color coordinates measured at center point of AMOLED.

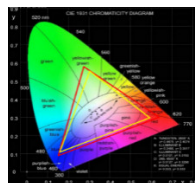

## 8. Interface Pin Assignment

### 8-1 TFT Pin Assignment

| Number | Signal    | Description                                 |
|--------|-----------|---------------------------------------------|
| 1      | GND       | Ground                                      |
| 2      | D0P       | MIPI Data Line                              |
| 3      | D0N       | MIPI Data Line                              |
| 4      | GND       | Ground                                      |
| 5      | D1P       | MIPI Data Line                              |
| 6      | D1N       | MIPI Data Line                              |
| 7      | GND       | Ground                                      |
| 8      | CLKP      | MIPI CLK Line                               |
| 9      | CLKN      | MIPI CLK Line                               |
| 10     | GND       | Ground                                      |
| 11     | D2P       | MIPI Data Line                              |
| 12     | D2N       | MIPI Data Line                              |
| 13     | GND       | Ground                                      |
| 14     | D3P       | MIPI Data Line                              |
| 15     | D3N       | MIPI Data Line                              |
| 16     | GND       | Ground                                      |
| 17     | TSP_INT   | Interrupt Signal for Touch Panel            |
| 18     | TSP_RESET | Reset Pin for Touch Panel                   |
| 19     | TSP_SCL   | Serial Clock Signal for Touch Panel I2C I/F |
| 20     | TSP_SDA   | Serial Data Signal for Touch Panel I2C I/F  |
| 21     | TSP_AVDD  | Analog Power for Touch Panel                |
| 22     | TSP_VDDIO | Digital Power for Touch Panel               |
| 23     | AVDD      | AMOLED charge pumping power for DDIC        |
| 24     | AVDD_EN   | AVDD enable                                 |
| 25     | SWIRE     | Control the PMIC                            |
| 26     | TE        | Tear Effect                                 |
| 27     | REST      | Drive IC reset                              |
| 28     | VDDIO     | AMOLED logic power for DDIC                 |
| 29     | GND       | Ground (or NA)                              |
| 30     | ELVSS     | AMOLED EL Negative power                    |
| 31     | ELVSS     |                                             |
| 32     | ELVSS     |                                             |
| 33     | GND       | Ground (or NA)                              |
| 34     | ELVDD     | AMOLED EL Positive power                    |
| 35     | ELVDD     |                                             |
| 36     | ELVDD     |                                             |
| 37     | MTP_PWR   | Power supply for MTP Programming or Erase   |
| 38     | VCI       | AMOLED logic power for DDIC                 |

|    |      |                             |
|----|------|-----------------------------|
| 39 | DVDD | AMOLED logic power for DDIC |
|----|------|-----------------------------|

Note: I=Input; O=Output; P=Power; I/O=Input / Output

### 8-2 TP FPC Pin Assignment

| No | Symbol    | I/O   | Description                      |
|----|-----------|-------|----------------------------------|
| 1  | GND       | GND   | Ground                           |
| 2  | TSP_AVDD  | Power | Analog Power for Touch Panel     |
| 3  | TSP_IOVCC | Power | Digital Power for Touch Panel    |
| 4  | TSP_INT   | O     | Interrupt signal for Touch Panel |
| 5  | TSP_SDA   | I/O   | SDA pin for Touch Panel          |
| 6  | TSP_SCL   | I     | SCL pin for Touch Panel          |
| 7  | TSP_RESET | I     | Reset Pin for Touch Panel        |
| 8  | GND       | GND   | Ground                           |

**9. Block Diagram**

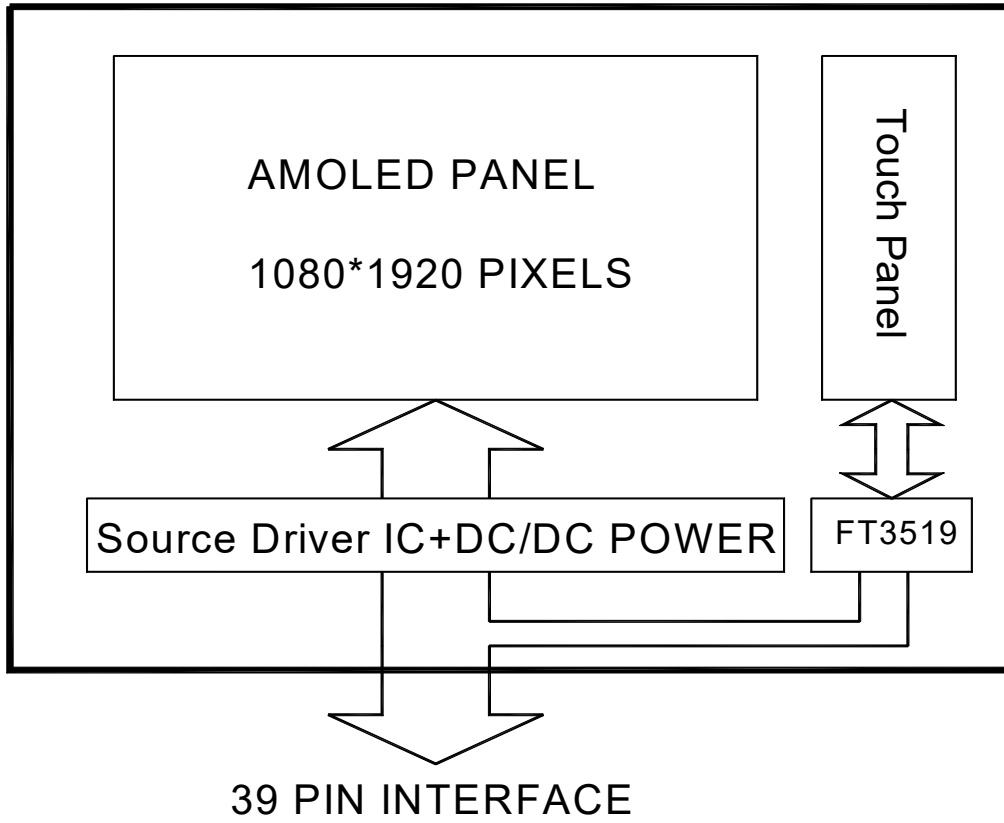

## 10. Environmental / Reliability Test

| No | Test Item                                  | Condition                                                         | Remark                                                                                |
|----|--------------------------------------------|-------------------------------------------------------------------|---------------------------------------------------------------------------------------|
| 1  | High Temperature Operation                 | +60°C, 120hrs                                                     | IEC60068-2-2,GB2423.2                                                                 |
| 2  | Low Temperature Operation                  | -20°C, 120hrs                                                     | IEC60068-2-1<br>GB2423.1                                                              |
| 3  | High Temperature Storage                   | +70°C, 120hrs                                                     | IEC60068-2-2<br>GB2423.2                                                              |
| 4  | Low Temperature Storage                    | -30°C, 120hrs                                                     | IEC60068-2-1<br>GB2423.1                                                              |
| 5  | High Temperature & High Humidity Operation | 60°C, 90% RH,120hrs                                               | IEC60068-2-78<br>GB/T2423.3                                                           |
| 6  | Thermal Shock (Non-operation)              | -40(°C)/30(min) ~+80 (°C)/30(min),<br>Change time:10min, 30Cycles | Start with cold temperature,<br>End with high temperature,<br>IEC60068-2-14,GB2423.22 |

**Note: Product reliability items in the form of GK are used as reference items. The test results shall refer to the results of the reliability test of standards.**

## **11. Quality Level**

### *11.1 AMOLED Module of Characteristic Inspection*

The environmental condition and visual inspection shall be conducted as below:

11.1.1 Test conditions: OLED is not light, cold white fluorescent lamp, illumination  $1000 \pm 200$ lux; OLED lighting source shall not be higher than 200lux, with black background around.

11.1.2 Inspection distance: the standard observation distance of all surfaces of the tested object is  $30\text{cm} \pm 5\text{cm}$ .

11.1.3 Inspection angle: the angle between the product and the horizontal plane is  $45^\circ$ , and the eyes are perpendicular to the inspection plane. During inspection, the product needs to rotate  $45^\circ$  up, down, left and right. The observation line of sight needs to be within the half section of the cone. The observation angle is  $45^\circ$  with the vertical axis of the product apex. The central axis of the cone must be standard and perpendicular to the product surface and pass through the fluorescent lamp; For non-conventional display defects (including but not limited to local bright lines or local floodlights), the observation angle is 75 degrees from the normal of the product surface; Full visual angle of appearance.

11.1.4 Inspection time: the inspection time without lighting is at least 10-12 seconds; The time of OLED lighting inspection for each picture is 1~3 seconds. If the defect is still not visible within the specified time, the inspection piece is deemed to be qualified.

11.1.5 Test temperature: room temperature  $15-35^\circ\text{C}$ , ambient humidity: 20-75% RH.

11.1.6 Inspection tools:

11.1.6.1 ND Filter: The ND Filter is placed at a distance of 2-3 cm above the defect for 2-3s to judge whether the defect is visible. As Figure below: (ND Filter is used to

test mura isochromatic and light

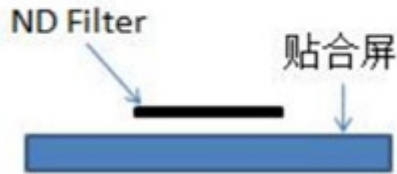

unevenness)

11.1.6.2 Point gauge (point gauge in the figure below is recommended), determination method: as shown in the figure, the point gauge film can cover is pass, and the point gauge film can not cover is Fail。 For example, a maximum of 0.2mm same-color spot defect is allowed on the Class A surface, and the pass that can be covered by 0.2mm on the film, The one that can be covered is Fail.



Imperfections of various shapes



Inspection Dot



**Pass:** Imperfection is smaller than the inspection dot



**Fail:** Imperfection is larger than the inspection dot

11.1.6.3 Microscopic examination: use 20-50 times adjustable microscope and 10-30 times test eyepiece.

11.1.6.4 Digital caliper: resolution 0.01mm.

11.1.6.5 Projector: anime microscope, 3D projector.

11.1.6.6 Judgment description



11.1.6.6.1 The measurement accuracy shall refer to the specification definition. When the measurement equipment accuracy is higher than the specification definition, the

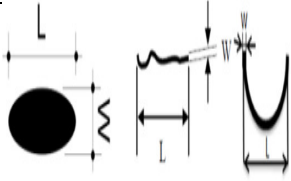

measured value needs to be rounded to the precision defined by the specification. For example, the size of edge collapse is 0.20mm, and the thousandth is the reference position, which is rounded to 0.200mm~0.204mm is OK,  $\geq 0.205$ mm, it is judged as NG.

11.1.6.6.2 In addition to the tools used above, if additional inspection tools are needed to assist the judgment, they can only be carried out after the coordination of both parties.

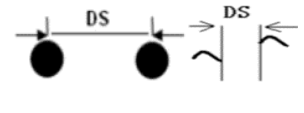
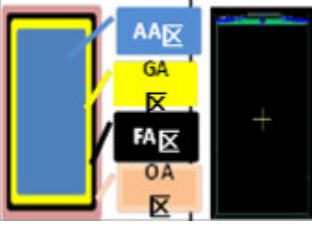
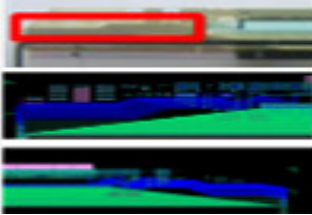
11.1.6.6.3 Bad code and definition

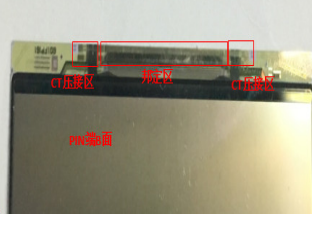
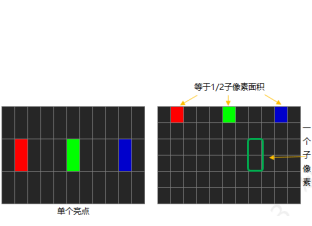
| Code and name |                              | legend                                                                              | explain                                                                                                                                                                                                                                                                                                                                              |
|---------------|------------------------------|-------------------------------------------------------------------------------------|------------------------------------------------------------------------------------------------------------------------------------------------------------------------------------------------------------------------------------------------------------------------------------------------------------------------------------------------------|
| N             | Number                       | -                                                                                   | Visually calculate the number; The statistics of the total number of defects does not include the completely "omitted" part. For the column defined as "omitted" and "omitted", it is not counted as the number of defects if it meets the requirements, otherwise it is calculated as an independent defect.                                        |
| L             | Length (mm)                  |  | Dot line distinguishing rule: L is the long side, W is the short side                                                                                                                                                                                                                                                                                |
| W             | Width (mm)                   |                                                                                     | A. When $L > 3W$ , handle as per line, otherwise handle as per point;<br>B. When it is judged as line defect, S-shaped or C-shaped line appears, and the enclosed amount is less than 3/4 circle, it shall be treated as line defect; otherwise, it shall be treated as point defect, and the inner tangent circle shall simulate the size of point. |
| S             | Area (mm <sup>2</sup> )      | -                                                                                   | Surface gauge                                                                                                                                                                                                                                                                                                                                        |
| D             | Diameter (mm)<br>$D=(L+W)/2$ | -                                                                                   | Point diameter calculation: calculated by half of the sum of the long side and the short side, that is, $D=(L+W)/2$ , where D represents the diameter of the point, L is the long side, and W is the short side;                                                                                                                                     |
| H             | Depth (mm)                   | -                                                                                   | Digital micrometer                                                                                                                                                                                                                                                                                                                                   |

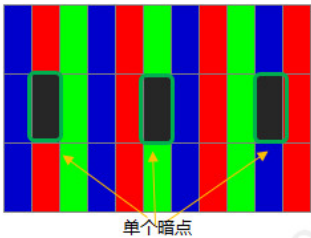
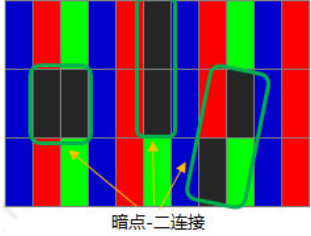
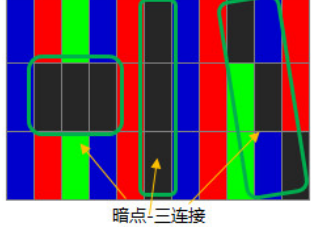
|                                  |                  |                                                                                     |                                                                                                                                                                                                                                                                                            |
|----------------------------------|------------------|-------------------------------------------------------------------------------------|--------------------------------------------------------------------------------------------------------------------------------------------------------------------------------------------------------------------------------------------------------------------------------------------|
| DS                               | Distance<br>(mm) |    | Distance between two points or between two lines                                                                                                                                                                                                                                           |
| Schematic diagram of screen area |                  |    | AA area: display area;<br>GA area: GIP circuit area;<br>FA area: Frit area;<br>OA area: outside FA area                                                                                                                                                                                    |
| Leader area                      |                  |    | Screen GIP circuit area, screen data circuit area                                                                                                                                                                                                                                          |
| PAD Bangding District            |                  |   | COG/FOG Bonding alignment mark and Bonding Pad on LTPS substrate                                                                                                                                                                                                                           |
| PAD Non-state area               |                  |  | Screen test pad, cutting area and lead-free area on LTPS substrate                                                                                                                                                                                                                         |
| CT crimping area                 |                  |  | Pin end screen test pad                                                                                                                                                                                                                                                                    |
| Highlights                       |                  |  | A single sub-pixel (or red, or green, or blue) of one pixel is called a point; The definition of bright spot is that in the environment of $200 \pm 50$ Lux, the pixels or dots seen by employees with naked eyes are always bright, and the bright spot is checked under the black screen |

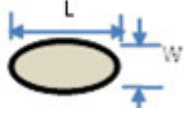
|                                   |                                                                                     |                                                                                                                                                                                                                                                                                                                                                             |
|-----------------------------------|-------------------------------------------------------------------------------------|-------------------------------------------------------------------------------------------------------------------------------------------------------------------------------------------------------------------------------------------------------------------------------------------------------------------------------------------------------------|
| <p>Scotoma</p>                    |    | <p>A single sub-pixel (or red, or green, or blue) of one pixel is called a point; A dark point is defined as a point that is not bright in a single sub-pixel seen with naked eyes in a 100% white picture under the environment of <math>200 \pm 50</math> Lux.</p>                                                                                        |
| <p>Dark spot - two connection</p> |    | <p>Two adjacent sub-pixels under the magnifying glass are not bright at the same time (horizontal, vertical and oblique)</p>                                                                                                                                                                                                                                |
| <p>Dark Spot - Three Links</p>    |    | <p>The adjacent R, G and B sub-pixels under the magnifying glass are not bright at the same time (horizontal, vertical and oblique)</p>                                                                                                                                                                                                                     |
| <p>CG monomer area division</p>   |  | <p>AA: Front visible area, black ink internal area;<br/>A: Black ink area;<br/>B: Cover plate edge;<br/>The front defect that runs through the AA area and the A area shall be judged according to the specification of the strictest area, and the back defect shall be judged according to whether the AA area is visible.</p>                            |
| <p>Foreign matter highlights</p>  | <p>-</p>                                                                            | <p>Due to the foreign matter in the polarizer, the phenomenon that appears as a bright spot is called a foreign matter bright spot</p>                                                                                                                                                                                                                      |
| <p>point defect</p>               |  | <p>There are bright spots and black spots in local positions, including but not limited to the internal dirt of the screen itself, pinholes, serrations, concave-convex spots, color spots, tiny bubbles, white spots, stains on the fitting of the polarizer, poor polarizer itself and other spot-like defects. Point defects are judged by diameter.</p> |

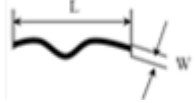
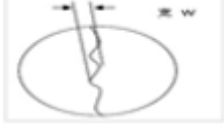
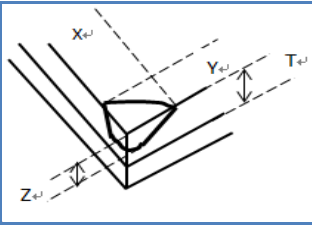
|                                     |                                                                                    |                                                                                                                                                                                                                                                                                                                                                                                                                                                                           |
|-------------------------------------|------------------------------------------------------------------------------------|---------------------------------------------------------------------------------------------------------------------------------------------------------------------------------------------------------------------------------------------------------------------------------------------------------------------------------------------------------------------------------------------------------------------------------------------------------------------------|
| <p>Linear defect</p>                |   | <p>Linear impurities in the screen, including filaments, fibers, polarizer fitting impurities in the screen, and scratches on the surface of polarizer, etc. Linear defects are judged by length and width. Sensible scratch: also known as hard scratch, is a deep scratch on the surface, which is felt by hand. Senseless scratch: also known as fine scratch, no deep scratch on the surface, no feeling when touching.</p>                                           |
| <p>Serrated defect</p>              |   | <p>W: Distance from sawtooth crest to trough</p>                                                                                                                                                                                                                                                                                                                                                                                                                          |
| <p>Edge collapse/angle collapse</p> |  | <p>In the process of screen production, especially in the process of molding and cutting, the small glass missing at the glass edge is caused.<br/> X direction: parallel to FOG Pad or glass edge;<br/> Y direction: perpendicular to FOG Pad or glass edge;<br/> Z direction: screen thickness direction;<br/> T: The thickness of single-layer glass;</p>                                                                                                              |
| <p>Pitting</p>                      | <p>-</p>                                                                           | <p>In the unit area of 10mm * 10mm, the defect point with <math>D \leq 0.1\text{mm}</math>, <math>DS \geq 2\text{mm}</math>, and the number <math>N \geq 5</math>. If the customer has other requirements, follow the customer's requirements.</p>                                                                                                                                                                                                                        |
| <p>Dirty</p>                        | <p>-</p>                                                                           | <p>Including handprints, oil stains, fingerprints, stains, white fog and other undesirable phenomena. It is divided into erasable dirt and non-erasable dirt. Use a dust-free cloth dipped in alcohol, which can not be erased as non-erasable dirt. Wipable dirt is determined as follows:<br/> A. Dry dust-free cloth can be directly erased;<br/> B. Wipe with clean cloth dipped with anhydrous alcohol<br/> Press the alcohol-stained dust-free cloth on the dry</p> |

|  |  |                                                                                                                                      |
|--|--|--------------------------------------------------------------------------------------------------------------------------------------|
|  |  | dust-free cloth twice to absorb excess alcohol;<br>Wipe back and forth with a dust-free cloth twice,<br>and the dirt can be removed. |
|--|--|--------------------------------------------------------------------------------------------------------------------------------------|

### 11.2 Sampling Procedures for Each Item Acceptance Table

Critical Defect (CR): any defect that directly or indirectly affects human health and safety, or the function of the product is lost.

Major Defect (MA): directly or indirectly affect the product function, or make part of the product function lost, and other customers do not acceptable defects.

Minor Defect (MI): appearance defect that does not affect product function and can be accepted by customers.

| Defect Type          | Sampling Procedures                                                                             | AQL   |
|----------------------|-------------------------------------------------------------------------------------------------|-------|
| Critical Defect (CR) | Take the normal inspection solution of the sampling plan of GB/T2828.1-2012 Inspection level II | 0.065 |
| Major Defect (MA)    | Take the normal inspection solution of the sampling plan of GB/T2828.1-2012 Inspection level II | 0.65  |
| Minor Defect (MI)    | Take the normal inspection solution of the sampling plan of GB/T2828.1-2012 Inspection level II | 1.0   |



### 11.3 Telecommunications Inspection Item

| category      | NO. | Inspection items     | Inspection specification                                                                   | test mode                    | defect type |
|---------------|-----|----------------------|--------------------------------------------------------------------------------------------|------------------------------|-------------|
| Poor function | 1   | Display exception    | not allow                                                                                  | visual                       | CR          |
|               | 2   | No display           | not allow                                                                                  | visual                       | CR          |
|               | 3   | The picture flickers | not allow                                                                                  | visual                       | MA          |
| TP function   | 4   | TP test NG           | not allow                                                                                  | visual                       | MA          |
| Dot           | 5   | Bright dot           | not allow                                                                                  | visual                       | MI          |
|               | 6   | Partial Bright dot   | ND6% or reference limit sample                                                             | visual                       | MI          |
|               | 7   | Dark dot             | 1.D≤0.15mm, ignored;<br>2.0.15mm<D≤ 0.2mm, DS<br>≥ 10mm, N ≤ 10;<br>3.D>0.2mm,not allowed; | Visual inspection,<br>Flinka | MI          |

|      |    |                      |                                                                                                                                                                         |                               |    |
|------|----|----------------------|-------------------------------------------------------------------------------------------------------------------------------------------------------------------------|-------------------------------|----|
| Line | 8  | Bright line          | not allow                                                                                                                                                               | visual                        | MA |
|      | 9  | Dark line            | not allow                                                                                                                                                               | visual                        | MA |
|      | 10 | Slightly bright line | not allow                                                                                                                                                               | visual                        | MA |
| Mura | 11 | horizontal mura      | No control under W64/127 screen; The 4%ND Filter on the 255 screen determines that the invisible is OK and the visible is NG.                                           | Visual ND Filter/limit sample | MI |
|      | 12 | vertical mura        | No control under W64/127 screen; The 4% ND Filter on the 255 screen determines that the invisible is OK and the visible is NG.                                          | Visual ND Filter/limit sample | MI |
|      | 13 | White spot           | No control under W64/127 screen; The 4% ND Filter on the 255 screen determines that the invisible is OK and the visible is NG.                                          | Visual ND Filter/limit sample | MI |
|      | 14 | Black spot           | No control under W64/127 screen; The 4% ND Filter on the 255 screen determines that the invisible is OK and the visible is NG.                                          | Visual ND Filter/limit sample | MI |
|      | 15 | Color mura           | 4% ND Filter in W64/255 screen determines that the invisible is OK and the visible is NG                                                                                | Visual ND Filter/limit sample | MI |
|      | 16 | snowflake            | No control under W64/127 screen; The 4% ND Filter on the 255 screen determines that the invisible is OK and the visible is NG.                                          | Visual ND Filter/limit sample | MI |
|      | 17 | Twill mura           | No control under W64/127 screen; The 4% ND Filter on the 255 screen determines that the invisible is OK and the visible is NG.                                          | Visual ND Filter/limit sample | MI |
|      | 18 | Newtonian ring       | No control under W64/127 screen; The 4% ND Filter on the 255 screen determines that the invisible is OK and the visible is NG.                                          | Visual ND Filter/limit sample | MI |
|      | 19 | Uneven transition    | Reference homogeneity standard to assist in judgment; The 4% ND Filter in the W64/255 screen determines that the invisible product is OK and the visible product is NG. | Visual ND Filter/limit sample | MI |

|                              |                                                                                                                                                                                                                                                                                                                                                             |                                                                             |                                |                          |    |
|------------------------------|-------------------------------------------------------------------------------------------------------------------------------------------------------------------------------------------------------------------------------------------------------------------------------------------------------------------------------------------------------------|-----------------------------------------------------------------------------|--------------------------------|--------------------------|----|
|                              | <p>1、 Mura all specify the screen judgment. For example, if the ELA mura judgment standard is 255, the ELA mura will only be judged on the W255 screen.</p> <p>2、 Other types of mura have a low adverse effect rate and low incidence. According to the 4% ND Filter in the W64/255 screen, the invisible products are OK and the visible ones are NG.</p> |                                                                             |                                |                          |    |
| Dot/line of foreign material | 20                                                                                                                                                                                                                                                                                                                                                          | Dot/line defects (foreign material, black white dot, scratch, bubble, etc.) | Same point/line specifications | Visual inspection/Flinka | MI |

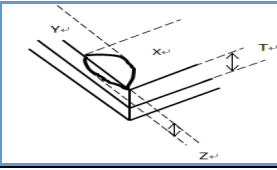
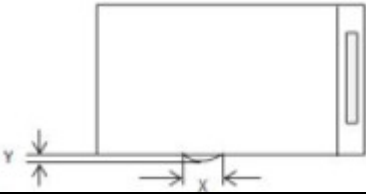
#### 11.4 Appearance Inspection Item

| NO. | Inspection items     | Surface Area  | Inspection specification                                                                                                                                                                                                                                                                                                                                                         | test mode                 | defect type |
|-----|----------------------|---------------|----------------------------------------------------------------------------------------------------------------------------------------------------------------------------------------------------------------------------------------------------------------------------------------------------------------------------------------------------------------------------------|---------------------------|-------------|
| 1   | Broken glass         | AA/OA         | not allow                                                                                                                                                                                                                                                                                                                                                                        | visual                    | MA          |
| 2   | crack                | AA/OA         | not allow                                                                                                                                                                                                                                                                                                                                                                        | visual                    | MA          |
| 3   | Edge collapse/corner | AA/OA         | <p>1. <math>Y \leq 0.15\text{mm}</math>, X and N are ignored;</p> <p>2. <math>0.15 &lt; Y \leq 0.4\text{mm}</math>, <math>X \leq 2\text{mm}</math>, N is ignored;</p> <p>3. <math>Y &gt; 0.4\text{mm}</math>, not allowed;</p> <p>4. <math>Z \leq t</math>, without damage to Frit body;</p>  | Visual inspection, Flinka | MI          |
| 4   | flange               | AA/OA         | <p>1. <math>Y \leq 0.2\text{mm}</math>, X is uncontrolled;</p> <p>2. <math>Y &gt; 0.2\text{mm}</math>, not allowed;</p>                                                                                                                                                                       | Visual inspection, Flinka | MI          |
| 5   | Glass warp           | Whole area    |  <p>The product is placed horizontally on the front and back, and the lifting height at one end (plug gauge) <math>\leq 0.6\text{mm}</math></p>                                                                                                                                               | Visual inspection, Flinka | MI          |
| 6   | Pin dirty            | Bongding area | No control                                                                                                                                                                                                                                                                                                                                                                       | visual                    | MI          |
| 7   | Pin scratch          | Bongding area | Scratches and whitening are found by visual inspection, and need to be rechecked with a microscope. The broken lead is not allowed, and the overlap is not allowed<br>Note: CT pad area and pin non-bonding area are not controlled                                                                                                                                              | visual                    | MI          |

|    |                                                           |      |                                                                                                                                                                 |                |                   |                           |                           |    |
|----|-----------------------------------------------------------|------|-----------------------------------------------------------------------------------------------------------------------------------------------------------------|----------------|-------------------|---------------------------|---------------------------|----|
| 8  | PF film bump                                              | LTPS | Touch is not allowed                                                                                                                                            |                |                   | visual                    | MI                        |    |
| 9  | PF film pinholes/pits                                     | LTPS | No control                                                                                                                                                      |                |                   | visual                    | MI                        |    |
| 10 | PF film scratch                                           | LTPS | 1. No scratch, no control; Scrape through, L<10mm;<br>2. The film shall be scraped through the exposed glass surface, referring to the lack of glue of PF film; |                |                   | Visual inspection, Flinka | MI                        |    |
| 11 | PF film lacks glue                                        | LTPS | 50> 5mm, W>5mm not allowed                                                                                                                                      |                |                   | Visual inspection, Flinka | MI                        |    |
| 12 | PF membrane is dirty                                      | LTPS | Wipable dirt needs to be wiped, and non-wipe dirt refers to the color difference of PF film;                                                                    |                |                   | visual                    | MI                        |    |
| 13 | PF film overflow                                          | LTPS | 1. Edge overflow W<0.2mm, acceptable;<br>2. W>0.2mm, not allowed;                                                                                               |                |                   | Visual inspection, Flinka | MI                        |    |
| 14 | Color difference/stain (no convex touch)                  | LTPS | No control                                                                                                                                                      |                |                   | visual                    | MI                        |    |
| 15 | PF film gluing offset                                     | LTPS | 1. Step area is not allowed;<br>2. Except for the step area, the rest shall be controlled by $0.5 \pm 0.2\text{mm}$ ;                                           |                |                   | Visual inspection, Flinka | MI                        |    |
| 16 | Screen body is dirty                                      | LTPS | 1. The front can be wiped and the dirt can be wiped, and the polarizer of the dirt cover cannot be wiped;<br>2. The back is not controlled;                     |                |                   | visual                    | MI                        |    |
| 17 | point defect                                              | AA   | D (mm)                                                                                                                                                          | DS (mm)        | Acceptable number | Visual inspection, Flinka | MI                        |    |
|    |                                                           |      | $D \leq 0.15\text{mm}$                                                                                                                                          | /              | Ignore            |                           |                           |    |
|    |                                                           |      | $0.15\text{mm} < D \leq 0.2\text{mm}$                                                                                                                           | $DS \geq 10$   | $N \leq 10$       |                           |                           |    |
| 18 | Linear defect/foreign matter linear/non-inductive scratch | AA   | W (mm)                                                                                                                                                          | L (mm)         | DS (mm)           | Acceptable number         | Visual inspection, Flinka | MI |
|    |                                                           |      | $W \leq 0.03$                                                                                                                                                   | $L \leq 5$     | $\geq 10$         | ignore                    |                           |    |
|    |                                                           |      | $0.03 < W \leq 0.05$                                                                                                                                            | $L \leq 2$     | $\geq 10$         | ignore                    |                           |    |
|    |                                                           |      | $0.03 < W \leq 0.05$                                                                                                                                            | $2 < L \leq 5$ | $\geq 10$         | $N \leq 4$                |                           |    |
|    |                                                           |      | $W > 0.05$                                                                                                                                                      | -              | /                 | Not allowed               |                           |    |

|    |                                            |                                  | -                                                                                                                              | L>5 | /                 | Not allowed |                           |    |
|----|--------------------------------------------|----------------------------------|--------------------------------------------------------------------------------------------------------------------------------|-----|-------------------|-------------|---------------------------|----|
| 19 | Point/Line defects                         | Camera hole area/Blind hole area | D(mm)                                                                                                                          |     | Acceptable number |             | Visual inspection, Flinka | MI |
|    |                                            |                                  | D≤0.15                                                                                                                         |     | ignore            |             |                           |    |
|    |                                            |                                  | 0.15<D≤0.2                                                                                                                     |     | ignore            |             |                           |    |
|    |                                            |                                  | D>0.2                                                                                                                          |     |                   |             |                           |    |
| 20 | Newton rings (Blind hole area)             | Camera hole area/Blind hole area | Not control                                                                                                                    |     |                   |             | Visual inspection         | MI |
| 21 | offset                                     | Camera hole area/Blind hole area | The metal ring extends inward 0.1mm ,ignore                                                                                    |     |                   |             | Visual inspection         | MI |
| 22 | Blind hole color bias(same color)          | Camera hole area/Blind hole area | Functional requirements such as transmittance and PV value are met,not control appearance                                      |     |                   |             | Visual inspection         | MI |
| 23 | Protective film scratch                    | Whole area                       | No control under no hurt boby                                                                                                  |     |                   |             | Visual inspection         | MI |
| 24 | Protective film starved/overflow glue/burr | Whole area                       | No control under no hurt boby                                                                                                  |     |                   |             | Visual inspection         | MI |
| 25 | Dirt inside the protective film            | Whole area                       | Not allowed                                                                                                                    |     |                   |             | Visual inspection         | MI |
| 26 | Easy to tear                               | Cover front                      | Function is invalid, damaged, leaked not allowed<br>Wrinkles, bumps, dirt, punching bad, burr, overflow glue is not controlled |     |                   |             | Visual inspection         | MI |
| 27 | Polarizer edge overflow                    | AA                               | W≤0.35mm , Not control;<br>W>0.35mm, Not allowed.                                                                              |     |                   |             | Visual inspection, Flinka | MI |
| 28 | Polarizer concave convex point             | AA                               | convex point: D≤0.2mm or refer to limit sample<br>concave point: D≤3mm, DS≥10mm, N≤3 or refer to limit sample                  |     |                   |             | Visual inspection, Flinka | MI |
| 29 | Polarizer fold / indentation               | AA                               | Does not affect the display as OK or refer to limit sample;                                                                    |     |                   |             | Visual inspection         | MI |
| 30 | Polarizer chromatism                       | AA                               | No control                                                                                                                     |     |                   |             | Visual inspection         | MI |

|    |                        |                      |                                                                                                                                                                                                                                                                                                                                                                                                                                                                                                                                                                                                                                                                                                                                                                                                                                                            |                   |    |
|----|------------------------|----------------------|------------------------------------------------------------------------------------------------------------------------------------------------------------------------------------------------------------------------------------------------------------------------------------------------------------------------------------------------------------------------------------------------------------------------------------------------------------------------------------------------------------------------------------------------------------------------------------------------------------------------------------------------------------------------------------------------------------------------------------------------------------------------------------------------------------------------------------------------------------|-------------------|----|
| 31 | IC chip                | IC                   | Not allowed                                                                                                                                                                                                                                                                                                                                                                                                                                                                                                                                                                                                                                                                                                                                                                                                                                                | Visual inspection | MI |
| 32 | FPC body defect        | FPC                  | <p>1. The parts on the FPC must be consistent with the product BOM table, and there are incorrect, multiple, or missing parts, which are not allowed; Polarities such as capacitors and inductors should not be soldered backwards or crooked;</p> <p>2. FPC scratches/scratches are based on the absence of exposed copper;</p> <p>3. Creases/Indentations: Indentations in the circuit area should not cause the back of the covering film to turn white; Non line area indentation should not cause FPC damage</p> <p>4. Except for the golden finger. FPC foreign object: a. Spot shape: <math>D \leq 0.5\text{mm}</math>, <math>N \leq 3</math>; b. Linear: length and width <math>\leq 0.3 * 5\text{mm}</math>;</p>                                                                                                                                  | Visual inspection | MI |
| 33 | FPC gold finger defect | Golden Finger Region | <p>1. Golden finger cracking: The length and width of the crack/damage at the top of the golden finger <math>\leq</math> the line width;</p> <p>2. Gold finger copper leakage: <math>W \leq 1/3</math> line width, <math>L \leq</math> line width, unlimited quantity</p> <p>3. Gold finger gap <math>W1 \leq 1/3</math> line width <math>W</math>, length <math>L1 \leq 1/2</math> line width <math>W</math>, unlimited quantity, all of the above conditions are met and allowed;</p> <p>4. Gold finger pressure/scratch should not expose copper, there should be no unevenness, and there should be no depth visible to the naked eye, which does not affect assembly and is acceptable;</p> <p>5. Gold fingers should not have sharp creases or dead folds;</p> <p>6. FPC gold fingers should not have oxidation, blackening, burns, or browning;</p> | Visual inspection | MI |
| 34 | connector              | connector            | There should be no tin or residual solder beads on the connector, and there should be no tin connection on the connector pins; PIN deformation shall be controlled within 0.05mm; Does not affect the lighting function; Visual inspection of pin breakage, pin detachment, and deformation of the outer frame is not allowed;                                                                                                                                                                                                                                                                                                                                                                                                                                                                                                                             | Visual inspection | MI |

|    |                 |                |                                                                                                                                                                                                                                                                                                                                                                                                                                                                                                                                                                                                                                                                                                                                                                                                                                                                                                                                                                                                                                                                                                                                                                                                                                                                                                                                                                                                                                                                                                                                                                                                                                                                                                                             |                   |    |
|----|-----------------|----------------|-----------------------------------------------------------------------------------------------------------------------------------------------------------------------------------------------------------------------------------------------------------------------------------------------------------------------------------------------------------------------------------------------------------------------------------------------------------------------------------------------------------------------------------------------------------------------------------------------------------------------------------------------------------------------------------------------------------------------------------------------------------------------------------------------------------------------------------------------------------------------------------------------------------------------------------------------------------------------------------------------------------------------------------------------------------------------------------------------------------------------------------------------------------------------------------------------------------------------------------------------------------------------------------------------------------------------------------------------------------------------------------------------------------------------------------------------------------------------------------------------------------------------------------------------------------------------------------------------------------------------------------------------------------------------------------------------------------------------------|-------------------|----|
| 35 | Insulating tape | Bonding area   | There must be no obvious wrinkles or bubbles                                                                                                                                                                                                                                                                                                                                                                                                                                                                                                                                                                                                                                                                                                                                                                                                                                                                                                                                                                                                                                                                                                                                                                                                                                                                                                                                                                                                                                                                                                                                                                                                                                                                                | Visual inspection | MI |
|    |                 | Component area | <ol style="list-style-type: none"> <li>1. Scratches and glue splashes are uncontrollable;</li> <li>2. Do not wipe dirt or dirt;</li> <li>3. The offset of the insulation tape should not exceed the edge of the product, and other requirements should be determined based on the drawing;</li> <li>4. Burr edges, no control over glue overflow;</li> <li>5. Damaged, incomplete, or missing labels are not allowed;</li> </ol>                                                                                                                                                                                                                                                                                                                                                                                                                                                                                                                                                                                                                                                                                                                                                                                                                                                                                                                                                                                                                                                                                                                                                                                                                                                                                            |                   |    |
| 36 | Composite tape  | All            | <ol style="list-style-type: none"> <li>1. It is not allowed for the composite tape to leak out of the edge of the screen body;</li> <li>2. Folding of composite tape, light leakage during assembly, or affecting assembly and thickness are not allowed;</li> <li>3. Damaged composite tape is not allowed;</li> <li>4. The size of the composite tape cutting defect does not meet the requirements of the drawing and cannot be controlled;</li> <li>5. Composite tape should not be wiped with dirt or foreign objects, and foreign objects should follow the dotted line standard;</li> <li>6. The burrs of the composite tape should not exceed the edge of the screen body, regardless of control;</li> <li>8. Composite adhesive tape with no control over glue splashes or overflow;</li> <li>9. Composite tape bubbles: <math>D \leq 5\text{mm}</math>, N not included;</li> <li>10. Composite tape bumps: acute angle bumps <math>D \leq 0.3\text{mm}</math>, <math>N \leq 3</math>; Smooth concave convex points <math>D \leq 0.8\text{mm}</math>, <math>N \leq 3</math>;</li> <li>11. Composite tape foreign object (foreign object between copper foil and blue film): <math>D \leq 0.3\text{mm}</math>, <math>N \leq 3</math>;</li> <li>12. Edge sawtooth of composite tape: <math>0.5 * 3\text{mm}</math>, <math>N \leq 3</math>;</li> <li>13. The color difference of the protective film in the composite tape is not controlled;</li> <li>14. Copper foil indentation and dead bending in composite tape are not allowed, which does not affect assembly and thickness control; Or reference limit sample;</li> <li>15. No control of foreign objects/dents in copper foil in composite tape;</li> </ol> | Visual inspection | MI |

|    |                       |         |                                                                                                                                                                                                                                                            |                                 |    |
|----|-----------------------|---------|------------------------------------------------------------------------------------------------------------------------------------------------------------------------------------------------------------------------------------------------------------|---------------------------------|----|
| 37 | OCA overflow          | All     | Not allowed within AA area;<br>Externally visible: Control standard $\leq$ 0.15mm                                                                                                                                                                          | Visual inspection               | MI |
| 38 | Sealing glue          | Pin     | 1. Broken adhesive is not allowed, and the circuit cannot be exposed.<br>2. The thickness of the colloid shall not be higher than the POL surface.<br>3. Bubble diameter < 1mm.<br>4. Other: According to the drawings and work instructions.              | Visual inspection               | MI |
| 39 | Conductive cloth      | All     | 1. Conductive cloth dirt: $D \leq 5\text{mm}$ , $N \leq 2$ ;<br>2. Conductive cloth bubbles: $D \leq 2\text{mm}$ , $N \leq 2$ ;<br>3. Conductive cloth foreign object: $D \leq 1\text{mm}$ , $N \leq 3$ ;<br>4. Folding of conductive fabric: $N \leq 2$ ; | Visual inspection               | MI |
| 40 | Copper foil           | All     | Copper foil sticking is not allowed to leak out of the edge of the screen body; Abnormal color of copper foil refers to standard samples/sealed samples, and damage is not allowed. Soft scratches on the surface are not controlled.                      | Visual inspection               | MI |
| 41 | QR code               | QR code | It is not allowed to be unable to scan or difficult to scan (recognition can only be achieved after three consecutive scans), with a clear appearance, no blurring, missing printing, and other defects                                                    | Visual inspection               | MI |
| 42 | Package               | Other   | Products should put into the anti-static trays, with non-overlapping, and the trays should be staggered placed.                                                                                                                                            | visual                          | -  |
|    |                       |         | Different products cannot be mixed into the same inner package.                                                                                                                                                                                            |                                 |    |
|    |                       |         | The package should not have obvious deformation or breakage .The printing labels type and quantity are correct.                                                                                                                                            |                                 |    |
|    |                       |         | The package should have QC signature. ROHS label is needed if the product is under ROHS control.                                                                                                                                                           |                                 |    |
| 43 | Boundary dimension NG | Other   | It is not allowed to exceed the dimensional tolerance required by the specifications and drawings                                                                                                                                                          | Calipers, measuring instruments | -  |

### 11.5 Inspection picture library

| Serial number | picture                                                                             | Picture name                  | Mainly judged as defective                               | remarks |
|---------------|-------------------------------------------------------------------------------------|-------------------------------|----------------------------------------------------------|---------|
| 1             |    | W_GRAD(64)<br>64 gray scale   | Point/line type, foreign matter<br>point/line, mura type | /       |
| 2             |    | W_GRAD(128)<br>128 gray scale | Point/line type, foreign matter<br>point/line, mura type | /       |
| 3             |    | WHITE<br>white                | Point/line type, foreign matter<br>point/line, mura type | /       |
| 4             |   | Black<br>black                | Bright spot, bright line, dark<br>mura                   | /       |
| 5             |  | RED<br>red                    | Point type, line type, foreign<br>matter point/line      | /       |
| 6             |  | GREEN<br>green                | Point type, line type, foreign<br>matter point/line      | /       |
| 7             |  | BLUE<br>blue                  | Point type, line type, foreign<br>matter point/line      | /       |

Note: The actual sequence and lock seconds of the screen can be adjusted according to the customer's requirements and the needs of the factory.

### 11.6 AMOLED Module of Characteristic Inspection

The environmental condition and visual inspection shall be conducted as below:

- (1) Ambient temperature: 20~26°C
- (2) Humidity: 55 ± 10%RH
- (3) Ambient light intensity of visual inspection: 800 ~ 1200 lux
- (4) Ambient light intensity of function inspection: ≤200 lux
- (5) Viewing Distance: 30 ± 5cm
- (6) Viewing angle (tolerance): ±30°
- (7) Inspection time: 10 ±2 sec

### 11.7 Sampling Procedures for each item acceptance table

| Defect type  | Sampling Procedures                                                                  | AQL  |
|--------------|--------------------------------------------------------------------------------------|------|
| Major defect | GB/T2828.1-2012 Inspection level II<br>normal inspection<br>single sample inspection | 0.65 |
| Minor defect | GB/T2828.1-2012 Inspection level II<br>normal inspection<br>single sample inspection | 1.0  |

Major defect:

Any defect may result in functional failure, or reduce the usability of product for its purpose, such as electrical failure, deformation and so on.

Minor defect

A defect does not reduce the usability of product for its intended purpose, such as dot defect and so on.

The criteria on major and/or minor judgment will be according with the classification of defects.

11.8 Inspection Item

| No | Item               | Area               | Criterion of Defect                                          |                    |            |                              | Defect type |
|----|--------------------|--------------------|--------------------------------------------------------------|--------------------|------------|------------------------------|-------------|
| 1  | Dot Defect         | AA                 | Type                                                         | DS                 |            | Acceptable number            | Minor       |
|    |                    |                    | Bright Dot                                                   | $\geq 10\text{mm}$ |            | 0                            |             |
|    |                    |                    | Dark Dot                                                     | $\geq 10\text{mm}$ |            | 10                           |             |
| 2  | No Display         | AA                 | /                                                            |                    |            | Not allowed                  | Major       |
| 3  | Abnormal Display   | AA                 | /                                                            |                    |            | Not allowed                  | Major       |
| 4  | Normally white     | AA                 | /                                                            |                    |            | Not allowed                  | Major       |
| 5  | Line defect        | AA                 | /                                                            |                    |            | Not allowed                  |             |
| 6  | Mura               | AA                 | Regardless of control                                        |                    |            |                              | Major       |
| 7  | Edge/Side breakage | OA                 | The following Criterion is applicable to any side (unit: mm) |                    |            |                              | Minor       |
|    |                    |                    | type                                                         | Z                  | X          | Y                            |             |
|    |                    |                    | /                                                            | $\leq T$           | $\leq 2.0$ | not extended to circuit Area |             |
|    |                    |                    |                                                              |                    |            | not extended to Frit         |             |
| 8  | Glass crack        | Whole area         | /                                                            |                    |            | Not allowed                  | Major       |
| 9  | Panel Scratch      | AA                 | W (mm)                                                       | L (mm)             | DS (mm)    | Acceptable number            | Minor       |
|    |                    |                    | $W \leq 0.03$                                                | $L < 5.0$          | $\geq 10$  | Ignore                       |             |
|    |                    |                    | $0.03 < W \leq 0.05$                                         | $L \leq 2.0$       | $\geq 10$  | Ignore                       |             |
|    |                    |                    |                                                              | $2.0 < L \leq 5.0$ | $\geq 10$  | 2                            |             |
|    |                    |                    | $0.05 < W$                                                   | -                  | 0          | 0                            |             |
|    |                    |                    | $L > 5.0$                                                    | 0                  | 0          |                              |             |
|    |                    | GA、FA、OA area      | W (mm)                                                       | L (mm)             | DS (mm)    | Acceptable number            | Minor       |
|    |                    |                    | $W \leq 0.03$                                                | Ignore             | $\geq 10$  | Ignore                       |             |
|    |                    |                    | $0.03 < W \leq 0.05$                                         | $L \leq 2.0$       | $\geq 10$  | Ignore                       |             |
|    |                    |                    |                                                              | $2.0 < L \leq 5.0$ | $\geq 10$  | 2                            |             |
|    |                    |                    | $0.05 < W$                                                   | -                  | 0          | 0                            |             |
|    |                    |                    | $L > 5.0$                                                    | 0                  | 0          |                              |             |
|    |                    | Circuit Area of OA | /                                                            |                    |            |                              | Not allowed |

|                     |                                                         |             |                                                                                                                    |                      |           |                   |       |
|---------------------|---------------------------------------------------------|-------------|--------------------------------------------------------------------------------------------------------------------|----------------------|-----------|-------------------|-------|
| 10                  | Frit Encapsulation                                      | FA          | Frit width can't be less than the design width of 9/10, without bubble or breakage.                                |                      |           |                   | Minor |
| 11                  | raised point                                            | Whole area  | /                                                                                                                  |                      |           | Not allowed       | Major |
| 12                  | Concave dot, Black and white dot, Polarizer Dent/Bubble | AA          | Front (Encap surface)                                                                                              | D (mm)               | DS (mm)   | Acceptable number | Minor |
|                     |                                                         |             |                                                                                                                    | $D \leq 0.20$        | $\geq 10$ | Ignore            |       |
|                     |                                                         |             |                                                                                                                    | $0.20 < D \leq 0.50$ | $\geq 10$ | 3                 |       |
|                     |                                                         |             | $0.50 < D$                                                                                                         | $\geq 10$            | 0         |                   |       |
| Rear (LTPS surface) | /                                                       | /           | Ignore                                                                                                             |                      |           |                   |       |
| 13                  | Polarizer Scratch/Fiber(Linear)                         | AA          | W (mm)                                                                                                             | L (mm)               | DS        | Acceptable number | Minor |
|                     |                                                         |             | $W \leq 0.03$                                                                                                      | Ignore               | $\geq 10$ | Ignore            |       |
|                     |                                                         |             | $0.03 < W \leq 0.05$                                                                                               | $L \leq 2.0$         | $\geq 10$ | Ignore            |       |
|                     |                                                         |             |                                                                                                                    | $2.0 < L \leq 5.0$   | $\geq 10$ | 3                 |       |
|                     |                                                         |             | $0.05 < W$                                                                                                         | -                    | $\geq 10$ | 0                 |       |
| -                   | $L > 5.0$                                               | $\geq 10$   | 0                                                                                                                  |                      |           |                   |       |
| 14                  | Panel dirt                                              | AA          | /                                                                                                                  | /                    | /         | Not allowed       | Minor |
| 15                  | UV                                                      | Not IC side | Over coating                                                                                                       |                      |           | Not allowed       | Minor |
|                     |                                                         | IC side     | The coating of IC side is not allowed higher than POL.                                                             |                      |           |                   |       |
| 16                  | Tuffy glue                                              | IC          | The coating is not allowed breakage or Bubble.                                                                     |                      |           | Major             |       |
|                     |                                                         |             | The coating is not allowed higher than POL.                                                                        |                      |           |                   |       |
|                     |                                                         | Other area  | Tuffy glue is not allowed to interrupt and the diameter of Bubble is not more than 0.5mm.                          |                      |           | Minor             |       |
|                     |                                                         |             | The coating is not allowed higher than POL.                                                                        |                      |           |                   |       |
| IC                  | Not allowed                                             |             |                                                                                                                    |                      |           |                   |       |
| 17                  | Package                                                 | other       | Products should put into the anti-static trays, with non-overlapping, and the trays should be staggered placed.    |                      |           | Minor             |       |
|                     |                                                         |             | Different products cannot be mixed into the same inner package.                                                    |                      |           |                   |       |
|                     |                                                         |             | The package should not have obvious deformation, breakage, and the printing, labels type and quantity are correct. |                      |           |                   |       |
|                     |                                                         |             | The package should have QC signature. ROHS label is needed if the products under ROHS control.                     |                      |           |                   |       |