

SPECIFICATION FOR AMOLED MODULE

MODULE NO: YB-OG194368S01A-N-A0

Doc.Version:00

Customer Approval:

<input type="checkbox"/> Accept	<input type="checkbox"/> Reject
---------------------------------	---------------------------------

YEEBO	NAME	SIGNATURE	DATE
Prepare	Mechanical Engineer		2024/7/25
Check	Electronic Engineer		
Verify			
Approval			

■ APPROVAL FOR SPECIFICATIONS ONLY

□ APPROVAL FOR SPECIFICATIONS AND SAMPLE

WIMRD005-02-D

2. Table of Contents

NO	CONTENTS	PAGE
1	Revision History	1
2	Table of Contents	2
3	Module Numbering System	3
4	General Specification	4
5	Dimensional Outline	5
6	Electrical Characteristics	6
7	Optical Characteristics	13
8	Interface Pin Assignment	15
9	Block Diagram	16
10	Environmental / Reliability Test	17
11	Quality Level	18

3. Module Numbering System
(example)

YB- T G 240320 S 01 D -T - A0

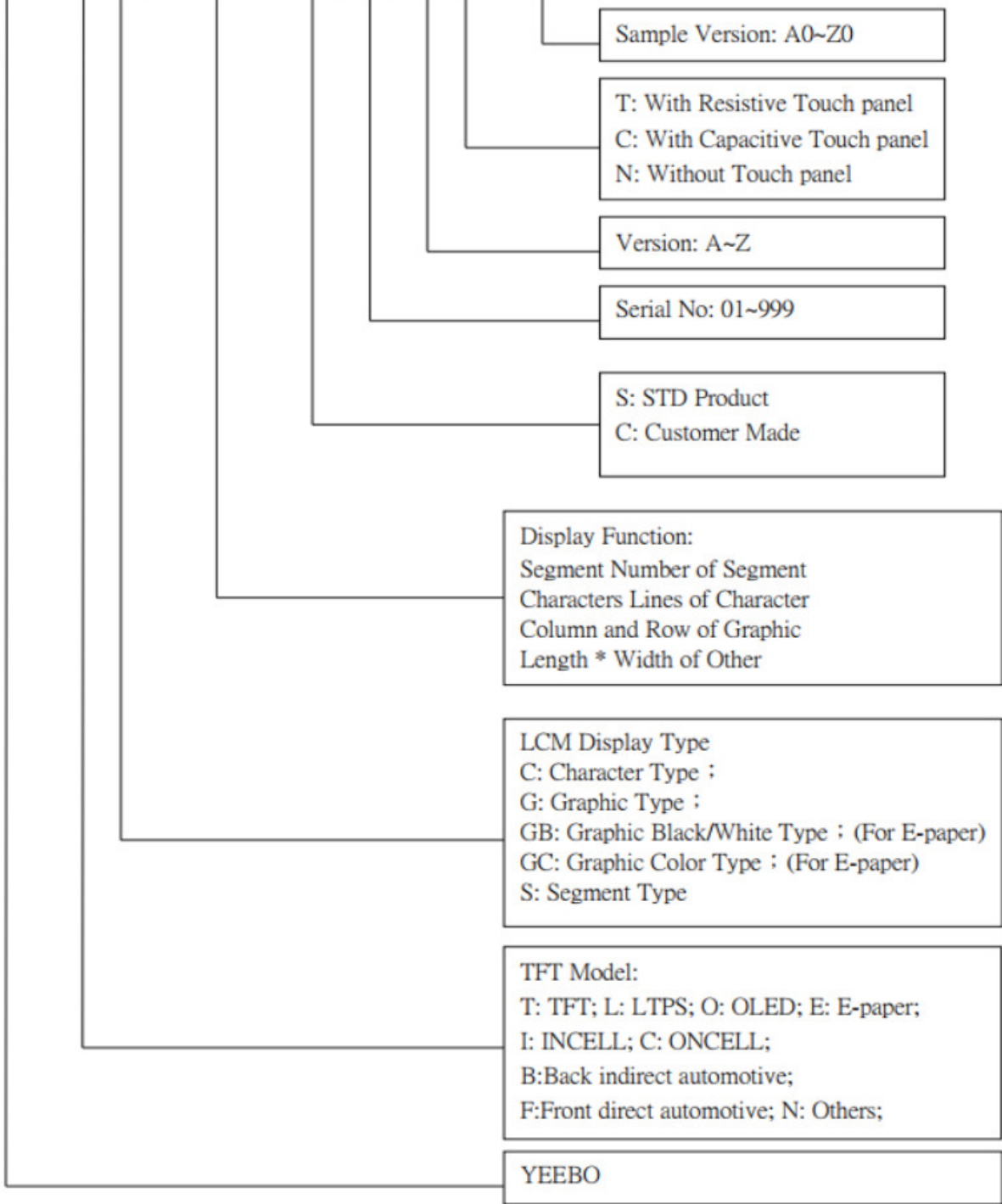

4. General Specification

TFT General Specification

Feature		Spec	Remark
Display Spec	Screen Size (inch)	1.46	
	Display Mode	AMOLED	
	Display method	Active Matrix TFT	
	Resolution(dot)	194(H) × 368(V)	
	Active Area(mm)	17.46 (W) × 33.12 (H)	
	Pixel Pitch (um)	0.090	
	Viewing Direction	All direction	
	Technology Type	LTPS	
	Color Depth	16.7M	
	Interface	Quad SPI	
Mechanical Characteristics	Polarizer Type	Hard coating: 3H, Glare	
	With TP/Without TP	With TP	
	Module Outline Dimension(W x H x D) (mm)	22.16mm*40.22mm*2.25Tmm	
Electronic	Driver IC(Type)	SH8501A	
	Touch IC(Type)	CHSC5816	
	Frame Rate	60HZ	

Note 1: Requirements on Environmental Protection: RoHS2.0.

5. Dimensional Outline

Rev.	01	Customer No.	
Revision content description	FIRST ISSUE	Date	2024-07-12

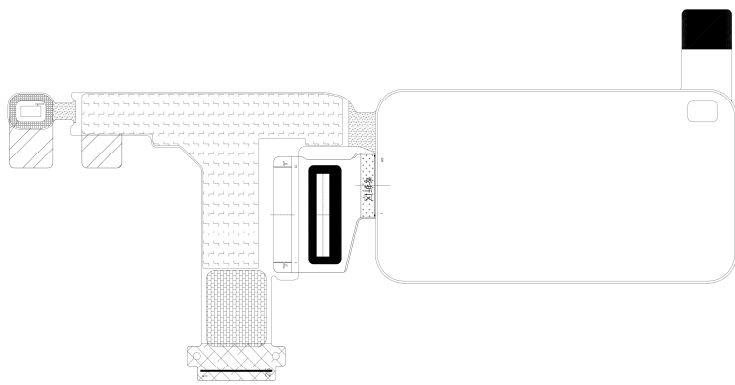
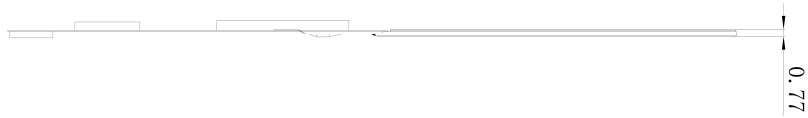
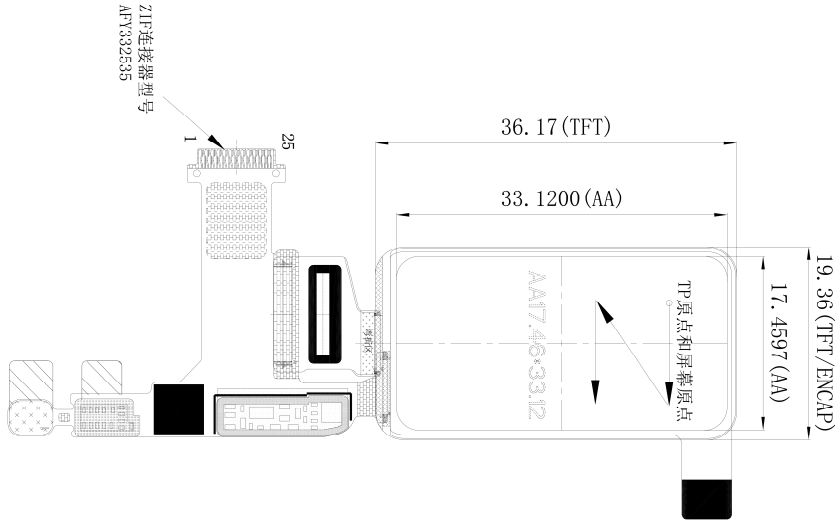

Pin No.	Pin Name
1	ALS_INT
2	ALS_SCL
3	ALS_SDA
4	ALS_VDD
5	TP_INT
6	TP_RST
7	TP_VDD (2.8V)
8	TP_SCL
9	TP_SDA
10	TP_AVDD (2.8V)
11	GND
12	VDD10
13	AM_GSP1_S13
14	AM_GSP1_S12
15	AM_GSP1_CSX
16	AM_GSP1_SCL
17	AM_GSP1_S11
18	AM_GSP1_S10
19	GND
20	REST
21	TE
22	VCI-FN
23	VBAT
24	MT2
25	GND

- NOTES:
1. 显示模组: 1.46" AMOLED, 不含盖板
 2. Driver IC: SH8501A, TP IC: CH5C5816; ZIF连接器型号: AFV332535, Power IC型号: SCM38045
 3. 产品符合RoHS.

YEEBO		MOD. Name	YB-OG194368S01A-N-A	Sheet	1
UNIT	SIZE	DESIGNED	CHECKED	VERIFIED	APPROVED
mm	A4				
SCALE		FILE NAME		Count Dwg.	
N:1-S					

Customer Approval

Customer NO.

6. Electrical Characteristics

6-1 Absolute Maximum Ratings

6-1-1

Item	Symbol	Values			Unit	Remark
		Min	Typ	max		
TP Power supply	TP_VCI	2.7	2.8	3.6	V	
TP I/O Supply Voltage	TP_VDD	1.7	1.8	1.95	V	
I/O Supply Voltage	AMOLED_VDDIO	1.7	1.8	1.95	V	
Battery power Voltage	AMOLED_VBAT	2.9	3.7	5.5	V	
VCI Voltage	AMOLED_VCI	3.1	3.3	3.5	V	Ripple $\leq\pm 20$ mV
EL supply voltage	ELVDD_Normal Mode	3.1	3.3	3.5	V	Ripple $\leq\pm 20$ mV
EL supply voltage	ELVSS_Normal Mode	-3.5	-3.3	-3.1	V	Ripple $\leq\pm 20$ mV
Input High Voltage	V _{IH}	0.8*VDD IO	-	VDDIO	V	
Input Low Voltage	V _{IL}	0	-	0.2*VDDIO	V	
Output High Voltage	V _{OH}	0.8*VDD IO	-	VDDIO	V	
Output Low Voltage	V _{OL}	0	-	0.2*VDDIO	V	
Frame Frequency(60H z)	fFRAME	58	60	62	Hz	@Room Temperature Command mode
Frame Frequency(30Hz)	fFRAME	28	30	32	Hz	
Frame Frequency(15H z)	fFRAME	14	15	16	Hz	

Note: If display manufacturer want to make MTP, please make sure that the MTP code can be covered by normal initialization code.

6-1-2 TP Absolute Maximum Ratings

Item	Symbol	MIN	MAX	Unit
TP power supply Input	TSP_AVDD	2.7	3.6	V
TP power supply for logic circuits	TSP_VDDIO	1.7	3.6	V

6-2 Operating Conditions

6-2-1 Driving AMOLED Panel

For Display panel with 450nits brightness;

Condition: ACL off, still pattern, Normal mode (not Seed mode)

Power Supply: TP_VCI=2.8V, TP_VDDI=1.8V, AMOLED_VCI=3.3V,

VBAT=3.7V, AMOLED_VDDI=1.8V, ELVDD =3.3V, ELVDSS=-3.3V

Frame Frequency: fFRAME=60Hz & 45Hz & 30Hz @ 25degC

Display Mode	Item	Typ	Max	Remark
		Power (mW)	Power (mW)	
100% Pixel On,450nits,60Hz	Normal mode	115	135	
100% Pixel On,450nits,45Hz	Normal mode	114	133	
100% Pixel On,450nits,30Hz	Normal mode	113	131	
All Pixel Off,0nits,60Hz	Normal mode	9.3	12	
All Pixel Off,0nits/Vci on/Vddio on	Standby mode	0.65	0.9	
All Pixel Off,0nits/ Vci off/Vddio on	Standby mode	0.01	0.05	
10% Pixel On,50nits, 15Hz	Idle mode	6.5	8.5	
10% Pixel On,100nits, 15Hz	Idle mode	8	9.5	
100% Pixel On,1000nits,60Hz	Boost mode	275	315	

6-2-3 TP Operating Conditions

Power Supply: TP_VCI=2.8V, TP_VDDI=1.8V, AMOLED_VCI=3.3V,

AMOLED_VDDI=1.8V,

Report Rate: 120Hz and 60Hz @ DISPLAY Frame Frequency =60Hz (FW version:

xxxxxxx)

	Finger	Report rate	Symbol	Value		Unit	Remark
				Typ	Max		
Touch Mode	1 fingers	60Hz	P	4.4	5.5	mW	1.With 1 Finger 60HZ Report rate 2.Base on 60HZ, and VCI 2.8V,1.47" circular shaped module; 3. TP 厂需 100%进 行 电流监控.
Idle (AOD)	Gesture	20Hz	P	93	113	uW	支持手势唤醒
Sleep	Sleep	/	P	17	30	uW	

6-2-4 TP General Specifications

Item	Item	Specification	Description	Remark
1	Middle Pitch	≤ 4.8 mm	Be suitable for X-direction and Y-direction	
2	Trace design	Tx&Rx routing	Tx single routing Rx single routing	
		Channel quantity:	Tx: ≥4 Rx: ≥7	
3	Max Trace Resistance	≤1KΩ	1. The Maximum Trace resistance 2. Max-Min <200ohm	
4	Resistance between Chanel	> 100K		
5	Bridge material and quantity	≥2ea/node (Metal Mesh)		
6	Capacitance Sensitivity	≥10%	Delta value/raw data*100% Diff Rate≤10%	Note 7.12
7	Raw Capacitance Uniformity	≤ 15%	The raw capacitance value between different area should be similar, (Max-Min)/(Max raw data)	Note 7.13
8	Signal Uniformity at different position	Diff Rate≤±TBD%	Use ø9mm copper touch on screen, the uniformity of capacitance delta value in the whole screen	Note 7.14
9	Signal Uniformity at Different sensing frequency	Shift Rate ≤10%	Separately fix TP sensing frequency at 300KHz and 400KHz and judge if their raw data difference is in the spec or not	Note 7.15
10	Touch in the VA area	Interference Rate ≤3%	Use ø9mm copper touch in the VA area, the interference in other area.	Note 7.16
11	Touch out of the VA area	Interference Rate ≤3%	Out of the VA area use ø 9mm copper touch, the interference in the TP VA area;	Note 7.17
12	Metal mesh	Metal Mesh :		
	sheet Resistance	≤0.07ohm/sq.		
13	Space of Metal mesh	≤5um		
14	ITO sheet Resistance	TBD		

15	Capacitive raw data limited spec	Avg. \pm 25% (without manual calibration)(without notch and corner area)		
16	Mutual Capacitance	$C_m \leq 1.0\text{pF}$	Capacitance between Tx and Rx	
		$\Delta C_m \geq 0.07\text{pF}$	Delta capacitance after put a 9mm finger on the sensor	
17	Self-Capacitance	Capacitance between Tx and Cathode $\leq 500\text{pF}$		
		Capacitance between Rx and Cathode $\leq 350\text{pF}$		
18	Guard trace design	Guard trace width $\geq 2 \times \text{Rx}$ Trace width		
		Space $\geq 2 \times \text{Rx}$ Trace width	The space between Guard trace and Tx or between Guard trace and Rx trace	
		$C_{tx/rx} \leq 20\% C_m$	$C_{tx/rx}$: The Capacitance between Tx and Rx trace (contain sensor trace and COF/FPC trace)	

6-3AC Characteristics

Quad SPI 24bit Data Format

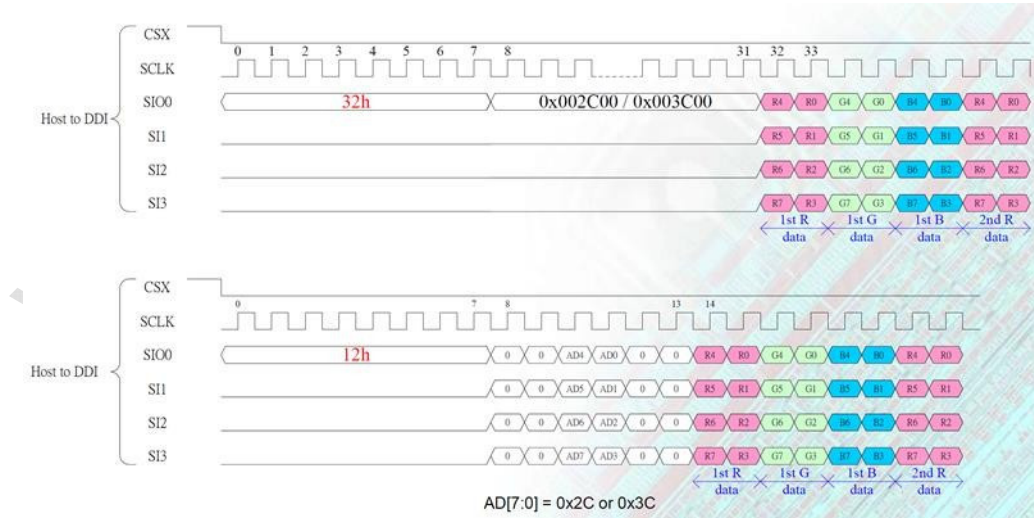

Display panel Power on/off Sequence

Power On sequence

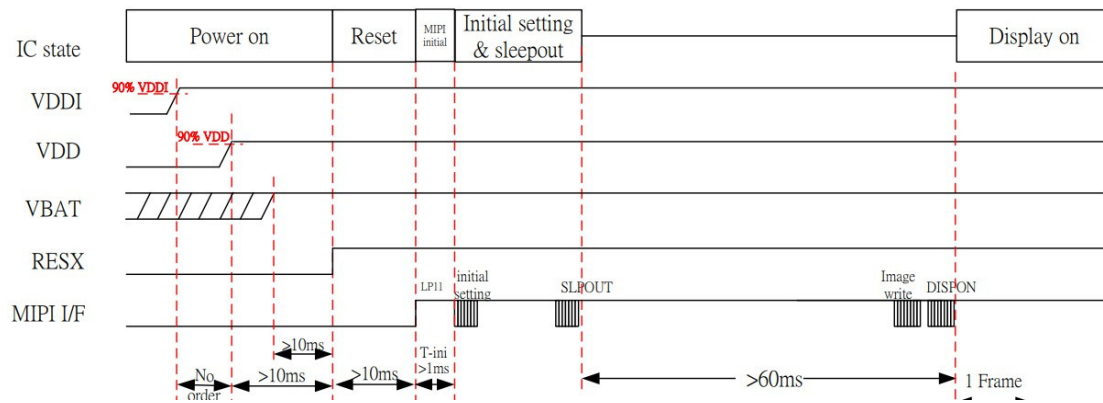

Power Off sequence

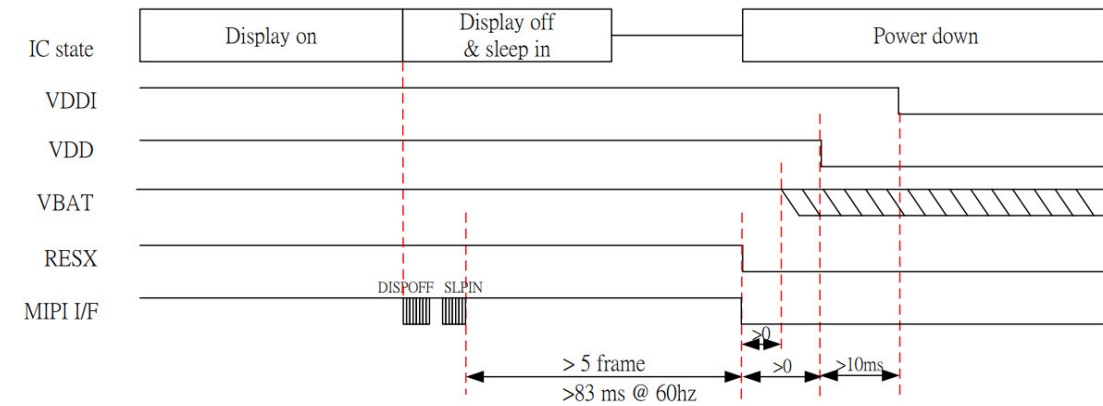

Display panel reset timing

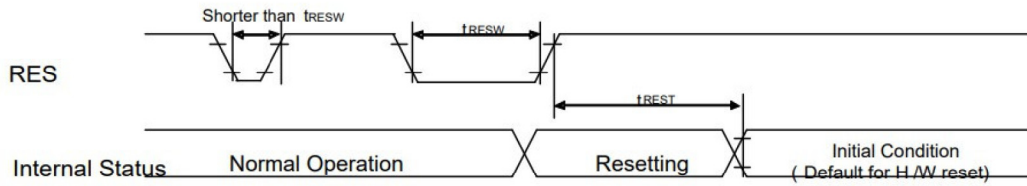

Reset input timing:

VDDI=1.65 to 3.3V, VDD=2.7 to 3.6V, AGND=DGND=0V, Ta=-40 to 85°C

Symbol	Parameter	Related Pins	MIN	TYP	MAX	Note	Unit
t _{RESW}	*1) Reset low pulse width	RESX	10	-	-	-	μs
t _{REST}	*2) Reset complete time	-	-	-	10	When reset applied during Sleep in mode	ms
		-	-	-	120	When reset applied during Sleep out mode	ms

t_{RESW} shorter than 5us, Reset will be rejected.

Quad SPI Interface Characteristics

1-wire mode:

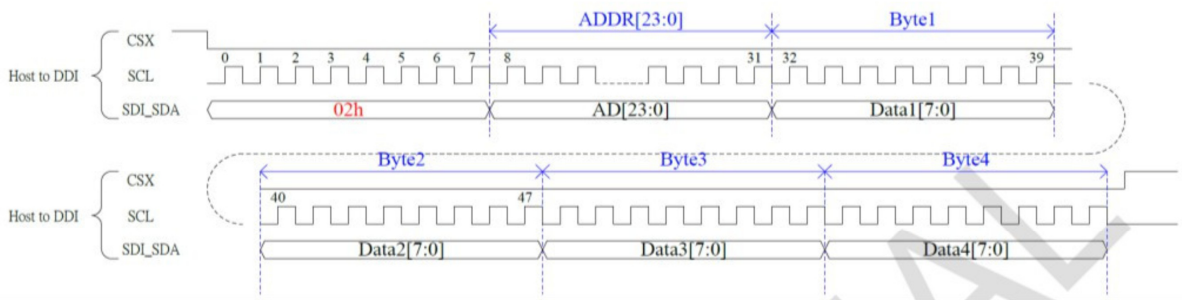

4-wire mode:

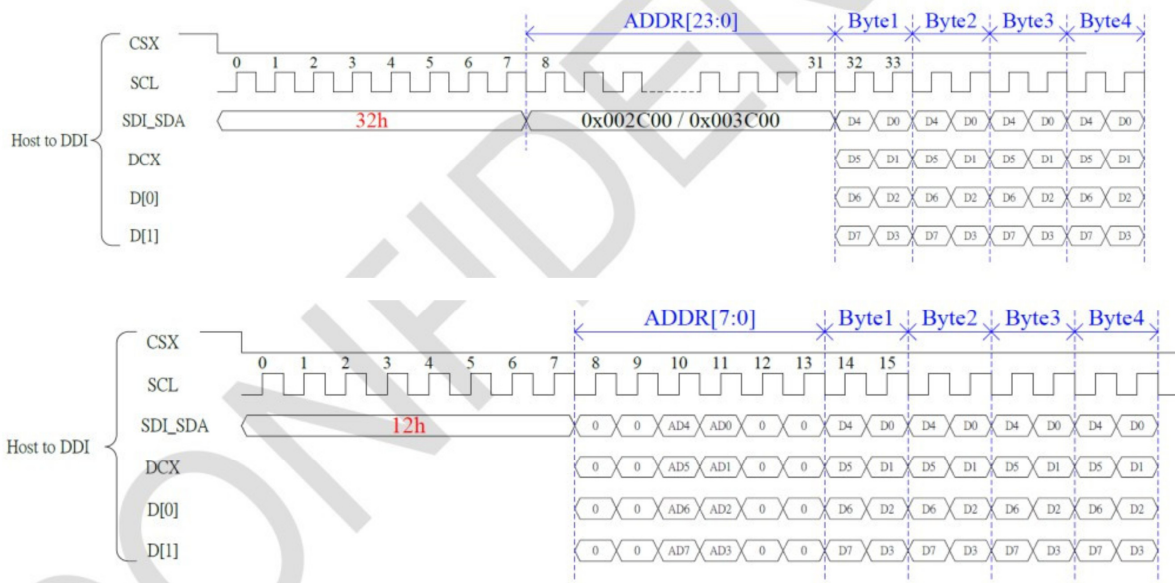

TP_VCI/IOVCC/VSP/VSN at Power on/off sequence

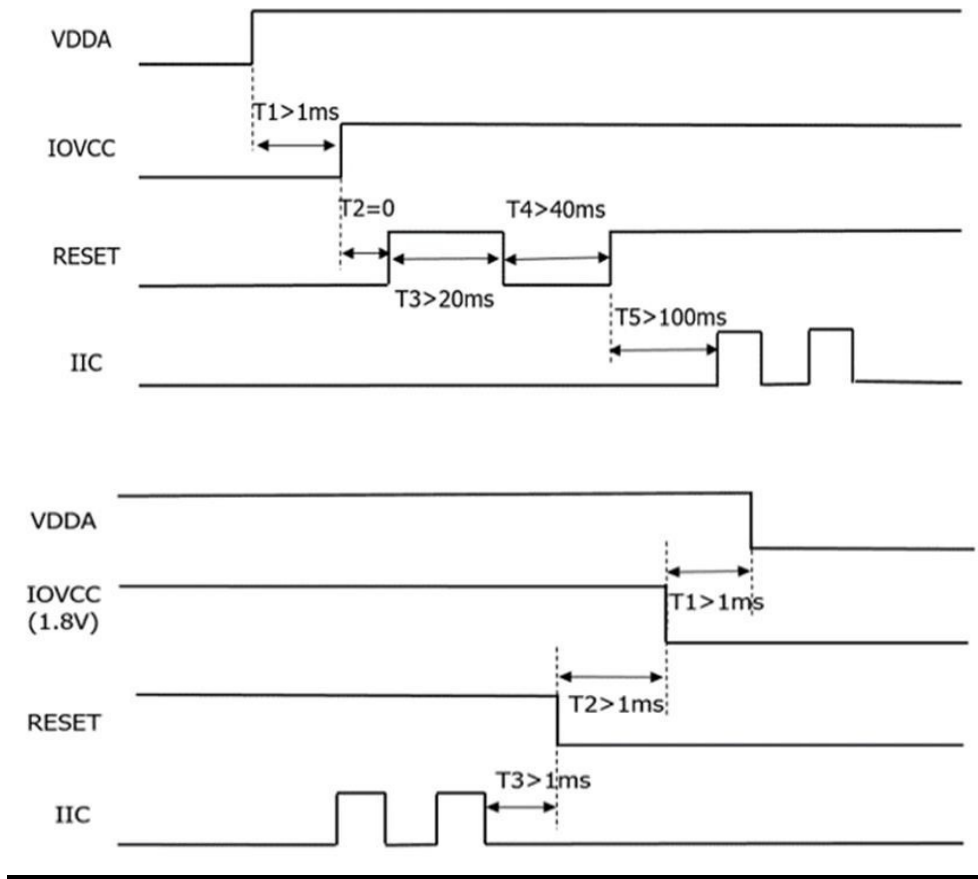

TP reset timing

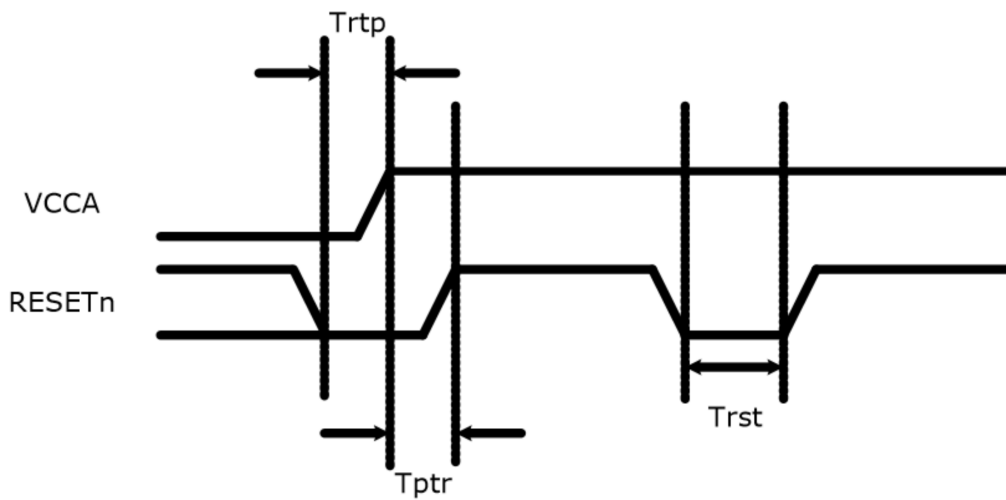

SYMBOL	PARAMETER	MIN	MAX	UNIT
T_{rtp}	Reset to low time before power-on	0	-	us
T_{ptr}	Reset time after power-on	1	-	ms
T_{rst}	Reset time	1	-	ms

7. Optical Characteristics

Item	Symbol	Condition	Value			Unit	Remarks
			Min	Typ	Max		
Luminance (Normal mode with lens)	Bp-Normal	$\theta=0^\circ$ $\phi=0^\circ$	400	450	--	cd/m ²	Note 6.1.1 CPK \geq 1.33 Center point value; write max value when OTP All monitored during MP
Luminance (HBM mode with lens)	Bp-HBM		900	1000	--	cd/m ²	
Maximum Brightness of Black Pattern (@Normal and HBM mode)	Bblk*				0.001	cd/m ²	Based on CS2000
Luminance Uniformity	Δ Bp		85	--	--	%	Note 6.1.2
Note 6.1.3	Left	θ L	Cr \geq 10	80	--	--	deg
	Right	θ R		80	--	--	
	Top	ψ T		80	--	--	
	Bottom	ψ B		80	--	--	

Note 6.1.4	Cr	$\theta=0^\circ$ $\phi=0^\circ$	100000	--	--	-	
Response Time	Tr		-	2	3	ms	Note 6.1.5
	Tf		-	2	3	ms	
	Tgray		-	2	3	ms	
Color Coordinate 1 of CIE1931 (with lens for Normal/HBM/AOD mode)	Red	Rx	$\theta=0^\circ$ $\phi=0^\circ$	0.655	0.685	0.715	CIE 1931
		Ry		0.285	0.315	0.345	
	Green	Gx		0.195	0.235	0.275	
		Gy		0.685	0.725	0.765	
	Blue	Bx		0.113	0.143	0.173	
		By		0.015	0.045	0.075	
	White	Wx		0.28	0.30	0.32	
		Wy		0.29	0.31	0.33	

Test Conditions:

1. The ambient temperature is 25°C.
2. The test systems refer to Note1 and Note2.

Note 1: Definition of optical measurement system.

The optical characteristics should be measured in dark room. The optical properties are measured at the center point of the AMOLED screen. All input terminals AMOLED panel must be ground when measuring the center area of the panel.

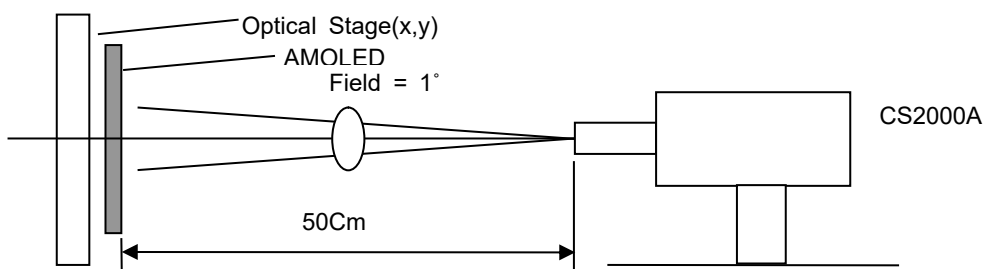

Note 2: Definition of color chromaticity (CIE1931)

Color coordinates measured at center point of AMOLED.

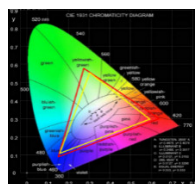

8. Interface Pin Assignment

Pin No.	I/O	Symbol	Description	Note
1	I/O	ALS-INT	ALS-INT	
2	I/O	ALS-SCL	ALS I2C CLK	
3	I/O	ALS-SDA	ALS I2C Data	
4	Power	ALS-VDD	1.8V power for ALS	
5	I/O	TP_INT	TP INT	
6	I/O	TP_RES	TP Reset	
7	Power	TP_VDD(1.8V)	1.8V power for TP	
8	I/O	TP_SCL	TP I2C CLK	
9	I/O	TP_SDA	TP I2C Data	
10	Power	TP_AVDD(2.8V)	2.8V power for TP	
11	Power	GND	Ground	
12	Power	VDDIO	OLED Power supply for interface system	
13	I/O	AM_QSPI_SI3	OLED QSPI interface	
14	I/O	AM_QSPI_SI2	OLED QSPI interface	
15	I/O	AM_QSPI_CSX	OLED QSPI interface	
16	I/O	AM_QSPI_SCL	OLED QSPI interface	
17	I/O	AM_QSPI_SI1	OLED QSPI interface	
18	I/O	AM_QSPI_SI0	OLED QSPI interface	
19	Power	GND	Ground	
20	I	REST	OLED Device reset signal	
21	O	TE	Synchronous signal output from panel to avoid tearing effect	
22	Power	VCI_EN	AMOLED power	
23	Power	VBAT	AMOLED power	
24	--	MTP	Floating	
25	Power	GND	Ground	

9. Block Diagram

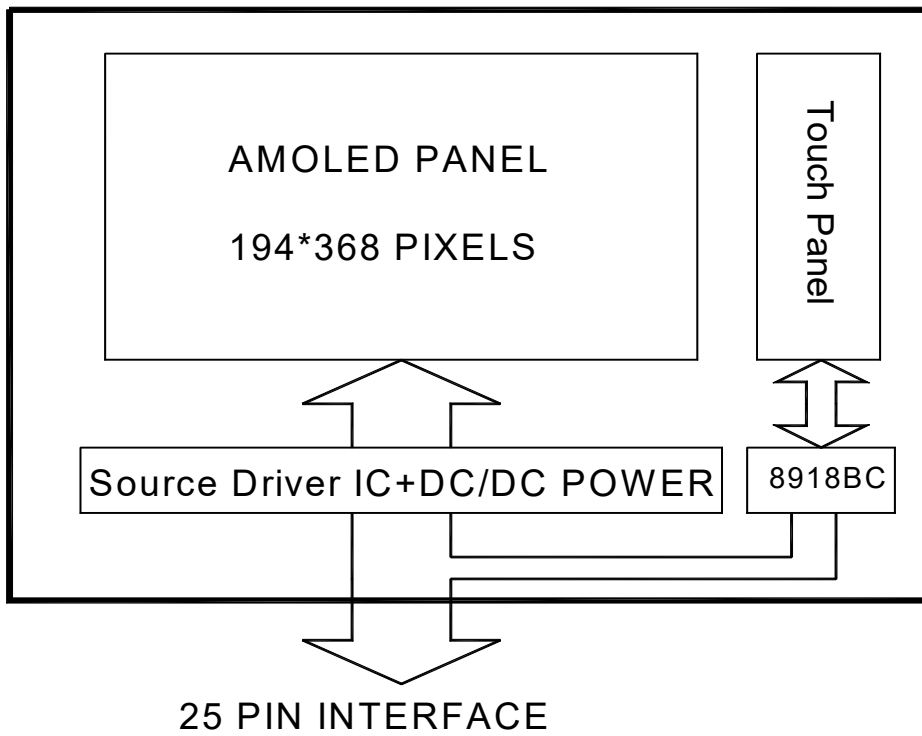

10. Environmental / Reliability Test

No	Test Item	Condition	Remark
1	High Temperature Operation	+70°C, 120hrs	IEC60068-2-2,GB2423.2
2	Low Temperature Operation	-20°C, 120hrs	IEC60068-2-1 GB2423.1
3	High Temperature Storage	+80°C, 120hrs	IEC60068-2-2 GB2423.2
4	Low Temperature Storage	-40°C, 120hrs	IEC60068-2-1 GB2423.1
5	High Temperature & High Humidity Operation	60°C, 90% RH,120hrs	IEC60068-2-78 GB/T2423.3
6	Thermal Shock (Non-operation)	-40(°C)/30(min) ~+80 (°C)/30(min), Change time:10min, 30Cycles	Start with cold temperature, End with high temperature, IEC60068-2-14,GB2423.22

Note: Product reliability items in the form of GK are used as reference items. The test results shall refer to the results of the reliability test of standards.

11. Quality Level

11.1 AMOLED Module of Characteristic Inspection

The environmental condition and visual inspection shall be conducted as below:

11.1.1 Test conditions: OLED is not light, cold white fluorescent lamp, illumination 1000 ± 200 lux; OLED lighting source shall not be higher than 200lux, with black background around.

11.1.2 Inspection distance: the standard observation distance of all surfaces of the tested object is $30\text{cm} \pm 5\text{cm}$.

11.1.3 Inspection angle: the angle between the product and the horizontal plane is 45° , and the eyes are perpendicular to the inspection plane. During inspection, the product needs to rotate 45° up, down, left and right. The observation line of sight needs to be within the half section of the cone. The observation angle is 45° with the vertical axis of the product apex. The central axis of the cone must be standard and perpendicular to the product surface and pass through the fluorescent lamp; For non-conventional display defects (including but not limited to local bright lines or local floodlights), the observation angle is 75 degrees from the normal of the product surface; Full visual angle of appearance.

11.1.4 Inspection time: the inspection time without lighting is at least 10-12 seconds; The time of OLED lighting inspection for each picture is 1~3 seconds. If the defect is still not visible within the specified time, the inspection piece is deemed to be qualified.

11.1.5 Test temperature: room temperature $15-35^\circ\text{C}$, ambient humidity: 20-75% RH.

11.1.6 Inspection tools:

11.1.6.1 ND Filter: The ND Filter is placed at a distance of 2-3 cm above the defect for 2-3s to judge whether the defect is visible. As Figure below: (ND Filter is used to

test mura isochromatic and light

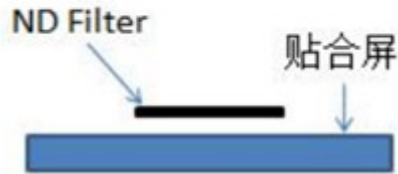

unevenness)

11.1.6.2 Point gauge (point gauge in the figure below is recommended), determination method: as shown in the figure, the point gauge film can cover is pass, and the point gauge film can not cover is Fail。 For example, a maximum of 0.2mm same-color spot defect is allowed on the Class A surface, and the pass that can be covered by 0.2mm on the film, The one that can be covered is Fail.



Imperfections of various shapes



Inspection Dot



Pass: Imperfection is smaller than the inspection dot



Fail: Imperfection is larger than the inspection dot

11.1.6.3 Microscopic examination: use 20-50 times adjustable microscope and 10-30 times test eyepiece.

11.1.6.4 Digital caliper: resolution 0.01mm.

11.1.6.5 Projector: anime microscope, 3D projector.

11.1.6.6 Judgment description



11.1.6.6.1 The measurement accuracy shall refer to the specification definition. When the measurement equipment accuracy is higher than the specification definition, the

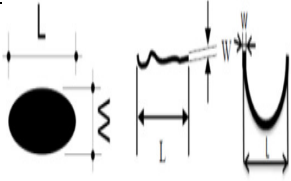

measured value needs to be rounded to the precision defined by the specification. For example, the size of edge collapse is 0.20mm, and the thousandth is the reference position, which is rounded to 0.200mm~0.204mm is OK, ≥ 0.205 mm, it is judged as NG.

11.1.6.6.2 In addition to the tools used above, if additional inspection tools are needed to assist the judgment, they can only be carried out after the coordination of both parties.

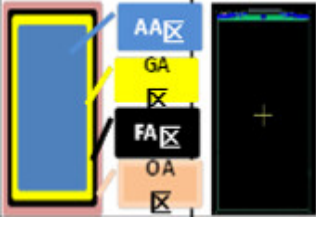
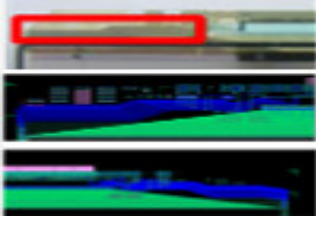
11.1.6.6.3 Bad code and definition

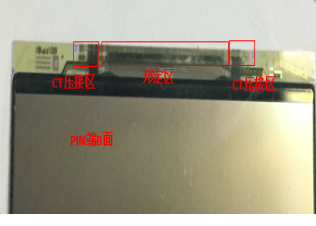
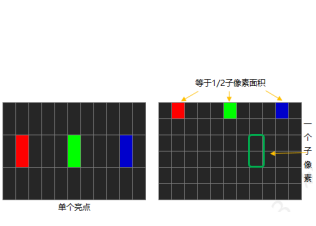
Code and name		legend	explain
N	Number	-	Visually calculate the number; The statistics of the total number of defects does not include the completely "omitted" part. For the column defined as "omitted" and "omitted", it is not counted as the number of defects if it meets the requirements, otherwise it is calculated as an independent defect.
L	Length (mm)		Dot line distinguishing rule: L is the long side, W is the short side
W	Width (mm)		A. When $L > 3W$, handle as per line, otherwise handle as per point; B. When it is judged as line defect, S-shaped or C-shaped line appears, and the enclosed amount is less than 3/4 circle, it shall be treated as line defect; otherwise, it shall be treated as point defect, and the inner tangent circle shall simulate the size of point.
S	Area (mm ²)	-	Surface gauge
D	Diameter (mm) $D=(L+W)/2$	-	Point diameter calculation: calculated by half of the sum of the long side and the short side, that is, $D=(L+W)/2$, where D represents the diameter of the point, L is the long side, and W is the short side;
H	Depth (mm)	-	Digital micrometer

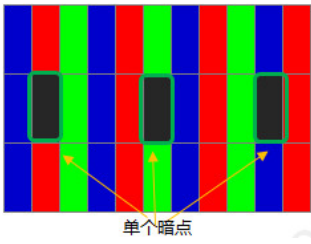
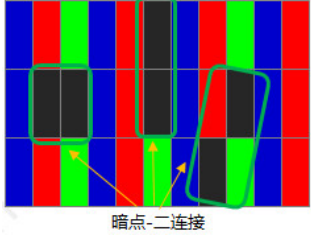
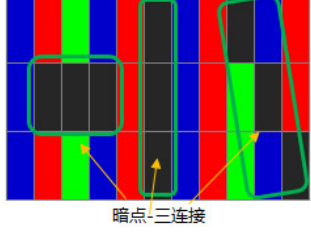
DS	Distance (mm)		Distance between two points or between two lines
Schematic diagram of screen area			AA area: display area; GA area: GIP circuit area; FA area: Frit area; OA area: outside FA area
Leader area			Screen GIP circuit area, screen data circuit area
PAD Bangding District			COG/FOG Bonding alignment mark and Bonding Pad on LTPS substrate
PAD Non-state area			Screen test pad, cutting area and lead-free area on LTPS substrate
CT crimping area			Pin end screen test pad
Highlights			A single sub-pixel (or red, or green, or blue) of one pixel is called a point; The definition of bright spot is that in the environment of 200 ± 50 Lux, the pixels or dots seen by employees with naked eyes are always bright, and the bright spot is checked under the black screen

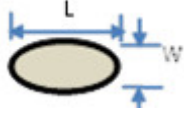
<p>Scotoma</p>		<p>A single sub-pixel (or red, or green, or blue) of one pixel is called a point; A dark point is defined as a point that is not bright in a single sub-pixel seen with naked eyes in a 100% white picture under the environment of 200 ± 50 Lux.</p>
<p>Dark spot - two connection</p>		<p>Two adjacent sub-pixels under the magnifying glass are not bright at the same time (horizontal, vertical and oblique)</p>
<p>Dark Spot - Three Links</p>		<p>The adjacent R, G and B sub-pixels under the magnifying glass are not bright at the same time (horizontal, vertical and oblique)</p>
<p>CG monomer area division</p>		<p>AA: Front visible area, black ink internal area; A: Black ink area; B: Cover plate edge; The front defect that runs through the AA area and the A area shall be judged according to the specification of the strictest area, and the back defect shall be judged according to whether the AA area is visible.</p>
<p>Foreign matter highlights</p>	<p>-</p>	<p>Due to the foreign matter in the polarizer, the phenomenon that appears as a bright spot is called a foreign matter bright spot</p>
<p>point defect</p>		<p>There are bright spots and black spots in local positions, including but not limited to the internal dirt of the screen itself, pinholes, serrations, concave-convex spots, color spots, tiny bubbles, white spots, stains on the fitting of the polarizer, poor polarizer itself and other spot-like defects. Point defects are judged by diameter.</p>

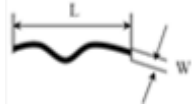
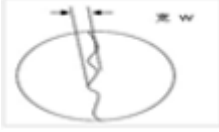
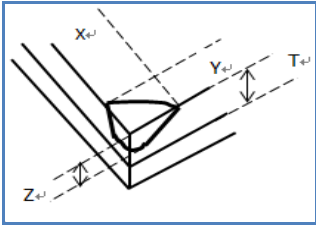
<p>Linear defect</p>		<p>Linear impurities in the screen, including filaments, fibers, polarizer fitting impurities in the screen, and scratches on the surface of polarizer, etc. Linear defects are judged by length and width. Sensible scratch: also known as hard scratch, is a deep scratch on the surface, which is felt by hand. Senseless scratch: also known as fine scratch, no deep scratch on the surface, no feeling when touching.</p>
<p>Serrated defect</p>		<p>W: Distance from sawtooth crest to trough</p>
<p>Edge collapse/angle collapse</p>		<p>In the process of screen production, especially in the process of molding and cutting, the small glass missing at the glass edge is caused. X direction: parallel to FOG Pad or glass edge; Y direction: perpendicular to FOG Pad or glass edge; Z direction: screen thickness direction; T: The thickness of single-layer glass;</p>
<p>Pitting</p>	<p>-</p>	<p>In the unit area of 10mm * 10mm, the defect point with $D \leq 0.1\text{mm}$, $DS \geq 2\text{mm}$, and the number $N \geq 5$. If the customer has other requirements, follow the customer's requirements.</p>
<p>Dirty</p>	<p>-</p>	<p>Including handprints, oil stains, fingerprints, stains, white fog and other undesirable phenomena. It is divided into erasable dirt and non-erasable dirt. Use a dust-free cloth dipped in alcohol, which can not be erased as non-erasable dirt. Wipable dirt is determined as follows: A. Dry dust-free cloth can be directly erased; B. Wipe with clean cloth dipped with anhydrous alcohol Press the alcohol-stained dust-free cloth on the dry</p>

		dust-free cloth twice to absorb excess alcohol; Wipe back and forth with a dust-free cloth twice, and the dirt can be removed.
--	--	--

11.2 Sampling Procedures for Each Item Acceptance Table

Critical Defect (CR): any defect that directly or indirectly affects human health and safety, or the function of the product is lost.

Major Defect (MA): directly or indirectly affect the product function, or make part of the product function lost, and other customers do not acceptable defects.

Minor Defect (MI): appearance defect that does not affect product function and can be accepted by customers.

Defect Type	Sampling Procedures	AQL
Critical Defect (CR)	Take the normal inspection solution of the sampling plan of GB/T2828.1-2012 Inspection level II	0.065
Major Defect (MA)	Take the normal inspection solution of the sampling plan of GB/T2828.1-2012 Inspection level II	0.65
Minor Defect (MI)	Take the normal inspection solution of the sampling plan of GB/T2828.1-2012 Inspection level II	1.0



11.3 Telecommunications Inspection Item

category	NO.	Inspection items	Inspection specification	test mode	defect type
Poor function	1	Display exception	not allow	visual	CR
	2	No display	not allow	visual	CR
	3	The picture flickers	not allow	visual	MA
TP function	4	TP test NG	not allow	visual	MA
Dot	5	Bright dot	not allow	visual	MI
	6	Partial Bright dot	ND6% or reference limit sample	visual	MI
	7	Dark dot	1.D≤0.15mm, ignored; 2.0.15mm<D≤0.2mm, DS ≥10mm, N≤10; 3.D>0.2mm,not allowed;	Visual inspection, Flinka	MI

Line	8	Bright line	not allow	visual	MA
	9	Dark line	not allow	visual	MA
	10	Slightly bright line	not allow	visual	MA
Mura	11	horizontal mura	No control under W64/127 screen; The 4%ND Filter on the 255 screen determines that the invisible is OK and the visible is NG.	Visual ND Filter/limit sample	MI
	12	vertical mura	No control under W64/127 screen; The 4% ND Filter on the 255 screen determines that the invisible is OK and the visible is NG.	Visual ND Filter/limit sample	MI
	13	White spot	No control under W64/127 screen; The 4% ND Filter on the 255 screen determines that the invisible is OK and the visible is NG.	Visual ND Filter/limit sample	MI
	14	Black spot	No control under W64/127 screen; The 4% ND Filter on the 255 screen determines that the invisible is OK and the visible is NG.	Visual ND Filter/limit sample	MI
	15	Color mura	4% ND Filter in W64/255 screen determines that the invisible is OK and the visible is NG	Visual ND Filter/limit sample	MI
	16	snowflake	No control under W64/127 screen; The 4% ND Filter on the 255 screen determines that the invisible is OK and the visible is NG.	Visual ND Filter/limit sample	MI
	17	Twill mura	No control under W64/127 screen; The 4% ND Filter on the 255 screen determines that the invisible is OK and the visible is NG.	Visual ND Filter/limit sample	MI
	18	Newtonian ring	No control under W64/127 screen; The 4% ND Filter on the 255 screen determines that the invisible is OK and the visible is NG.	Visual ND Filter/limit sample	MI
	19	Uneven transition	Reference homogeneity standard to assist in judgment; The 4% ND Filter in the W64/255 screen determines that the invisible product is OK and the visible product is NG.	Visual ND Filter/limit sample	MI

	<p>1、 Mura all specify the screen judgment. For example, if the ELA mura judgment standard is 255, the ELA mura will only be judged on the W255 screen.</p> <p>2、 Other types of mura have a low adverse effect rate and low incidence. According to the 4% ND Filter in the W64/255 screen, the invisible products are OK and the visible ones are NG.</p>				
Dot/line of foreign material	20	Dot/line defects (foreign material, black white dot, scratch, bubble, etc.)	Same point/line specifications	Visual inspection/Flinka	MI

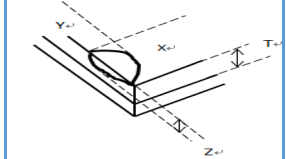
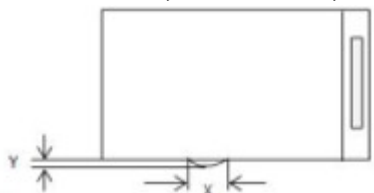
11.4 Appearance Inspection Item

NO.	Inspection items	Surface Area	Inspection specification	test mode	defect type
1	Broken glass	AA/OA	not allow	visual	MA
2	crack	AA/OA	not allow	visual	MA
3	Edge collapse/corner	AA/OA	<p>1. $Y \leq 0.15\text{mm}$, X and N are ignored;</p> <p>2. $0.15 < Y \leq 0.4\text{mm}$, $X \leq 2\text{mm}$, N is ignored;</p> <p>3. $Y > 0.4\text{mm}$, not allowed;</p> <p>4. $Z \leq t$, without damage to Frit body;</p> 	Visual inspection, Flinka	MI
4	flange	AA/OA	<p>1. $Y \leq 0.2\text{mm}$, X is uncontrolled;</p> <p>2. $Y > 0.2\text{mm}$, not allowed;</p> 	Visual inspection, Flinka	MI
5	Glass warp	Whole area	 <p>The product is placed horizontally on the front and back, and the lifting height at one end (plug gauge) $\leq 0.6\text{mm}$</p>	Visual inspection, Flinka	MI
6	Pin dirty	Bongding area	No control	visual	MI
7	Pin scratch	Bongding area	<p>Scratches and whitening are found by visual inspection, and need to be rechecked with a microscope. The broken lead is not allowed, and the overlap is not allowed</p> <p>Note: CT pad area and pin non-bonding area are not controlled</p>	visual	MI

8	PF film bump	LTPS	Touch is not allowed			visual	MI	
9	PF film pinholes/pits	LTPS	No control			visual	MI	
10	PF film scratch	LTPS	1. No scratch, no control; Scrape through, L<10mm; 2. The film shall be scraped through the exposed glass surface, referring to the lack of glue of PF film;			Visual inspection, Flinka	MI	
11	PF film lacks glue	LTPS	50> 5mm, W>5mm not allowed			Visual inspection, Flinka	MI	
12	PF membrane is dirty	LTPS	Wipable dirt needs to be wiped, and non-wipe dirt refers to the color difference of PF film;			visual	MI	
13	PF film overflow	LTPS	1. Edge overflow W<0.2mm, acceptable; 2. W>0.2mm, not allowed;			Visual inspection, Flinka	MI	
14	Color difference/stain (no convex touch)	LTPS	No control			visual	MI	
15	PF film gluing offset	LTPS	1. Step area is not allowed; 2. Except for the step area, the rest shall be controlled by $0.5 \pm 0.2\text{mm}$;			Visual inspection, Flinka	MI	
16	Screen body is dirty	LTPS	1. The front can be wiped and the dirt can be wiped, and the polarizer of the dirt cover cannot be wiped; 2. The back is not controlled;			visual	MI	
17	point defect	AA	D (mm)	DS (mm)	Acceptable number	Visual inspection, Flinka	MI	
			$D \leq 0.15\text{mm}$	/	Ignore			
			$0.15\text{mm} < D \leq 0.2\text{mm}$	$DS \geq 10$	$N \leq 10$			
18	Linear defect/foreign matter linear/non-inductive scratch	AA	W (mm)	L (mm)	DS (mm)	Acceptable number	Visual inspection, Flinka	MI
			$W \leq 0.03$	$L \leq 5$	≥ 10	ignore		
			$0.03 < W \leq 0.05$	$L \leq 2$	≥ 10	ignore		
			$0.03 < W \leq 0.05$	$2 < L \leq 5$	≥ 10	$N \leq 4$		
			$W > 0.05$	-	/	Not allowed		

			-	L>5	/	Not allowed		
19	Point/Line defects	Camera hole area/Blind hole area	D(mm)		Acceptable number		Visual inspection, Flinka	MI
			D≤0.15		ignore			
			0.15<D≤0.2		ignore			
			D>0.2					
20	Newton rings (Blind hole area)	Camera hole area/Blind hole area	Not control				Visual inspection	MI
21	offset	Camera hole area/Blind hole area	The metal ring extends inward 0.1mm ,ignore				Visual inspection	MI
22	Blind hole color bias(same color)	Camera hole area/Blind hole area	Functional requirements such as transmittance and PV value are met,not control appearance				Visual inspection	MI
23	Protective film scratch	Whole area	No control under no hurt boby				Visual inspection	MI
24	Protective film starved/overflow glue/burr	Whole area	No control under no hurt boby				Visual inspection	MI
25	Dirt inside the protective film	Whole area	Not allowed				Visual inspection	MI
26	Easy to tear	Cover front	Function is invalid, damaged, leaked not allowed Wrinkles, bumps, dirt, punching bad, burr, overflow glue is not controlled				Visual inspection	MI
27	Polarizer edge overflow	AA	W≤0.35mm , Not control; W>0.35mm, Not allowed.				Visual inspection, Flinka	MI
28	Polarizer concave convex point	AA	convex point: D≤0.2mm or refer to limit sample concave point: D≤3mm, DS≥10mm, N≤3 or refer to limit sample				Visual inspection, Flinka	MI
29	Polarizer fold / indentation	AA	Does not affect the display as OK or refer to limit sample;				Visual inspection	MI
30	Polarizer chromatism	AA	No control				Visual inspection	MI

31	IC chip	IC	Not allowed	Visual inspection	MI
32	FPC body defect	FPC	<p>1. The parts on the FPC must be consistent with the product BOM table, and there are incorrect, multiple, or missing parts, which are not allowed; Polarities such as capacitors and inductors should not be soldered backwards or crooked;</p> <p>2. FPC scratches/scratches are based on the absence of exposed copper;</p> <p>3. Creases/Indentations: Indentations in the circuit area should not cause the back of the covering film to turn white; Non line area indentation should not cause FPC damage</p> <p>4. Except for the golden finger. FPC foreign object: a. Spot shape: $D \leq 0.5\text{mm}$, $N \leq 3$; b. Linear: length and width $\leq 0.3 * 5\text{mm}$;</p>	Visual inspection	MI
33	FPC gold finger defect	Golden Finger Region	<p>1. Golden finger cracking: The length and width of the crack/damage at the top of the golden finger \leq the line width;</p> <p>2. Gold finger copper leakage: $W \leq 1/3$ line width, $L \leq$ line width, unlimited quantity</p> <p>3. Gold finger gap $W1 \leq 1/3$ line width W, length $L1 \leq 1/2$ line width W, unlimited quantity, all of the above conditions are met and allowed;</p> <p>4. Gold finger pressure/scratch should not expose copper, there should be no unevenness, and there should be no depth visible to the naked eye, which does not affect assembly and is acceptable;</p> <p>5. Gold fingers should not have sharp creases or dead folds;</p> <p>6. FPC gold fingers should not have oxidation, blackening, burns, or browning;</p>	Visual inspection	MI
34	connector	connector	There should be no tin or residual solder beads on the connector, and there should be no tin connection on the connector pins; PIN deformation shall be controlled within 0.05mm; Does not affect the lighting function; Visual inspection of pin breakage, pin detachment, and deformation of the outer frame is not allowed;	Visual inspection	MI

35	Insulating tape	Bonding area	There must be no obvious wrinkles or bubbles	Visual inspection	MI
		Component area	<ol style="list-style-type: none"> 1. Scratches and glue splashes are uncontrollable; 2. Do not wipe dirt or dirt; 3. The offset of the insulation tape should not exceed the edge of the product, and other requirements should be determined based on the drawing; 4. Burr edges, no control over glue overflow; 5. Damaged, incomplete, or missing labels are not allowed; 		
36	Composite tape	All	<ol style="list-style-type: none"> 1. It is not allowed for the composite tape to leak out of the edge of the screen body; 2. Folding of composite tape, light leakage during assembly, or affecting assembly and thickness are not allowed; 3. Damaged composite tape is not allowed; 4. The size of the composite tape cutting defect does not meet the requirements of the drawing and cannot be controlled; 5. Composite tape should not be wiped with dirt or foreign objects, and foreign objects should follow the dotted line standard; 6. The burrs of the composite tape should not exceed the edge of the screen body, regardless of control; 8. Composite adhesive tape with no control over glue splashes or overflow; 9. Composite tape bubbles: $D \leq 5\text{mm}$, N not included; 10. Composite tape bumps: acute angle bumps $D \leq 0.3\text{mm}$, $N \leq 3$; Smooth concave convex points $D \leq 0.8\text{mm}$, $N \leq 3$; 11. Composite tape foreign object (foreign object between copper foil and blue film): $D \leq 0.3\text{mm}$, $N \leq 3$; 12. Edge sawtooth of composite tape: $0.5 * 3\text{mm}$, $N \leq 3$; 13. The color difference of the protective film in the composite tape is not controlled; 14. Copper foil indentation and dead bending in composite tape are not allowed, which does not affect assembly and thickness control; Or reference limit sample; 15. No control of foreign objects/dents in copper foil in composite tape; 	Visual inspection	MI

37	OCA overflow	All	Not allowed within AA area; Externally visible: Control standard \leq 0.15mm	Visual inspection	MI
38	Sealing glue	Pin	1. Broken adhesive is not allowed, and the circuit cannot be exposed. 2. The thickness of the colloid shall not be higher than the POL surface. 3. Bubble diameter < 1mm. 4. Other: According to the drawings and work instructions.	Visual inspection	MI
39	Conductive cloth	All	1. Conductive cloth dirt: $D \leq 5\text{mm}$, $N \leq 2$; 2. Conductive cloth bubbles: $D \leq 2\text{mm}$, $N \leq 2$; 3. Conductive cloth foreign object: $D \leq 1\text{mm}$, $N \leq 3$; 4. Folding of conductive fabric: $N \leq 2$;	Visual inspection	MI
40	Copper foil	All	Copper foil sticking is not allowed to leak out of the edge of the screen body; Abnormal color of copper foil refers to standard samples/sealed samples, and damage is not allowed. Soft scratches on the surface are not controlled.	Visual inspection	MI
41	QR code	QR code	It is not allowed to be unable to scan or difficult to scan (recognition can only be achieved after three consecutive scans), with a clear appearance, no blurring, missing printing, and other defects	Visual inspection	MI
42	Package	Other	Products should put into the anti-static trays, with non-overlapping, and the trays should be staggered placed.	visual	-
			Different products cannot be mixed into the same inner package.		
			The package should not have obvious deformation or breakage .The printing labels type and quantity are correct.		
			The package should have QC signature. ROHS label is needed if the product is under ROHS control.		
43	Boundary dimension NG	Other	It is not allowed to exceed the dimensional tolerance required by the specifications and drawings	Calipers, measuring instruments	-

11.5 Inspection picture library

Serial number	picture	Picture name	Mainly judged as defective	remarks
1		W_GRAD(64) 64 gray scale	Point/line type, foreign matter point/line, mura type	/
2		W_GRAD(128) 128 gray scale	Point/line type, foreign matter point/line, mura type	/
3		WHITE white	Point/line type, foreign matter point/line, mura type	/
4		Black black	Bright spot, bright line, dark mura	/
5		RED red	Point type, line type, foreign matter point/line	/
6		GREEN green	Point type, line type, foreign matter point/line	/
7		BLUE blue	Point type, line type, foreign matter point/line	/

Note: The actual sequence and lock seconds of the screen can be adjusted according to the customer's requirements and the needs of the factory.

11.6 AMOLED Module of Characteristic Inspection

The environmental condition and visual inspection shall be conducted as below:

- (1) Ambient temperature: 20~26°C
- (2) Humidity: 55 ± 10%RH
- (3) Ambient light intensity of visual inspection: 800 ~ 1200 lux
- (4) Ambient light intensity of function inspection: ≤200 lux
- (5) Viewing Distance: 30 ± 5cm
- (6) Viewing angle (tolerance): ±30°
- (7) Inspection time: 10 ±2 sec

11.7 Sampling Procedures for each item acceptance table

Defect type	Sampling Procedures	AQL
Major defect	GB/T2828.1-2012 Inspection level II normal inspection single sample inspection	0.65
Minor defect	GB/T2828.1-2012 Inspection level II normal inspection single sample inspection	1.0

Major defect:

Any defect may result in functional failure, or reduce the usability of product for its purpose, such as electrical failure, deformation and so on.

Minor defect

A defect does not reduce the usability of product for its intended purpose, such as dot defect and so on.

The criteria on major and/or minor judgment will be according with the classification of defects.

11.8 Inspection Item

No	Item	Area	Criterion of Defect				Defect type
			Type	DS	Acceptable number		
1	Dot Defect	AA	Bright Dot	$\geq 10\text{mm}$	0	Minor	
			Dark Dot	$\geq 10\text{mm}$	10		
			/				Not allowed
2	No Display	AA	/				Major
3	Abnormal Display	AA	/				Major
4	Normally white	AA	/				Major
5	Line defect	AA	/				Major
6	Mura	AA	Regardless of control				Major
7	Edge/Side breakage	OA	The following Criterion is applicable to any side (unit: mm)				Minor
			type	Z	X	Y	
			/	$\leq T$	≤ 2.0	not extended to circuit Area	
						not extended to Frit	
8	Glass crack	Whole area	/				Major
9	Panel Scratch	AA	W (mm)	L (mm)	DS (mm)	Acceptable number	Minor
			$W \leq 0.03$	$L < 5.0$	≥ 10	Ignore	
			$0.03 < W \leq 0.05$	$L \leq 2.0$	≥ 10	Ignore	
				$2.0 < L \leq 5.0$	≥ 10	2	
			$0.05 < W$	-	0	0	
			$L > 5.0$	0	0		
		GA、FA、OA area	W (mm)	L (mm)	DS (mm)	Acceptable number	Minor
			$W \leq 0.03$	Ignore	≥ 10	Ignore	
			$0.03 < W \leq 0.05$	$L \leq 2.0$	≥ 10	Ignore	
				$2.0 < L \leq 5.0$	≥ 10	2	
			$0.05 < W$	-	0	0	
			$L > 5.0$	0	0		
		Circuit Area of OA	/				Not allowed

10	Frit Encapsulation	FA	Frit width can't be less than the design width of 9/10, without bubble or breakage.				Minor
11	raised point	Whole area	/			Not allowed	Major
12	Concave dot, Black and white dot, Polarizer Dent/Bubble	AA	Front (Encap surface)	D (mm)	DS (mm)	Acceptable number	Minor
				$D \leq 0.20$	≥ 10	Ignore	
				$0.20 < D \leq 0.50$	≥ 10	3	
			$0.50 < D$	≥ 10	0		
Rear (LTPS surface)	/	/	Ignore				
13	Polarizer Scratch/Fiber(Linear)	AA	W (mm)	L (mm)	DS	Acceptable number	Minor
			$W \leq 0.03$	Ignore	≥ 10	Ignore	
			$0.03 < W \leq 0.05$	$L \leq 2.0$	≥ 10	Ignore	
				$2.0 < L \leq 5.0$	≥ 10	3	
			$0.05 < W$	-	≥ 10	0	
-	$L > 5.0$	≥ 10	0				
14	Panel dirt	AA	/	/	/	Not allowed	Minor
15	UV	Not IC side	Over coating			Not allowed	Minor
		IC side	The coating of IC side is not allowed higher than POL.				
16	Tuffy glue	IC	The coating is not allowed breakage or Bubble.			Major	
			The coating is not allowed higher than POL.				
		Other area	Tuffy glue is not allowed to interrupt and the diameter of Bubble is not more than 0.5mm.			Minor	
			The coating is not allowed higher than POL.				
IC	Not allowed						
17	Package	other	Products should put into the anti-static trays, with non-overlapping, and the trays should be staggered placed.			Minor	
			Different products cannot be mixed into the same inner package.				
			The package should not have obvious deformation, breakage, and the printing, labels type and quantity are correct.				
			The package should have QC signature. ROHS label is needed if the products under ROHS control.				