

SPECIFICATION FOR TFT MODULE

MODULE NO: YB-TG800480S45A-N-A0

Doc.Version:00

Customer Approval:

<input type="checkbox"/> Accept	<input type="checkbox"/> Reject
---------------------------------	---------------------------------

YEEBO	NAME	SIGNATURE	DATE
Prepare	Electronic Engineer	黄松	2025-03-11
Check	Mechanical Engineer	张雷	2025/3/11
Verify			
Approval		孙亚南	2025/3/11

■ APPROVAL FOR SPECIFICATIONS ONLY

□ APPROVAL FOR SPECIFICATIONS AND SAMPLE

WIMRD005-02-D

2. Table of Contents:

NO	CONTENTS	PAGE
1	Revision History	1
2	Table of Contents	2
3	Module Numbering System	3
4	General Specification	4
5	LCM drawing	5
6	Electrical Characteristics	6
7	Optical Characteristics	13
8	Interface Pin Assignment	15
9	Block Diagram	16
10	Backlight	17
11	Standard Specification for Reliability	18
12	Specification of Quality Assurance	20
13	Handing Precaution	27
14	Warranty	28
15	Guarantee	28

3.Module Numbering System: (Example)

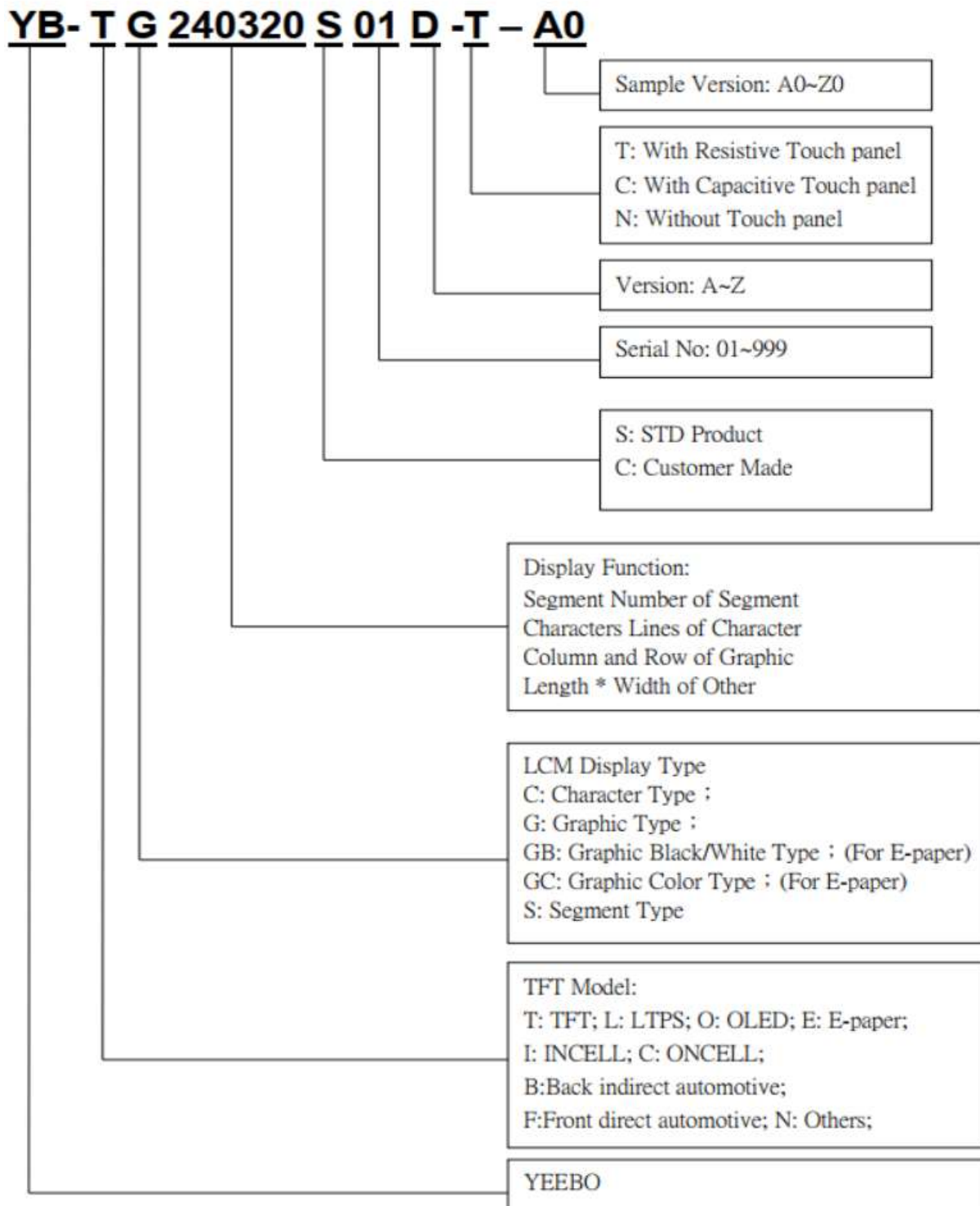

4. General Specification:

ITEM	CONTENTS
Module Size	116.2(W) * 74.65(H) *3.78(T) mm
Module Size(With FPC)	116.2(W) * 126.37(H) * 3.78(T) mm
Display Size(Diagonal)	5.0 inch
Display Format	800(RGB)* 480 Pixels
Active Area	108 (W) * 64.8 (H) mm
Pixel Pitch	0.135* 0.135 mm
LCD Type	TFT (16.7M)/Transmissive/ NB
Viewing Direction:	Free
Driver IC	ST72568-G6-L
Weight	TBD

5. LCM drawing:

Count drawing & Spec.revision record during discussion with customer	
Rec:	Revision content description
#1	FIRST ISSUE
Date	2025-03-09

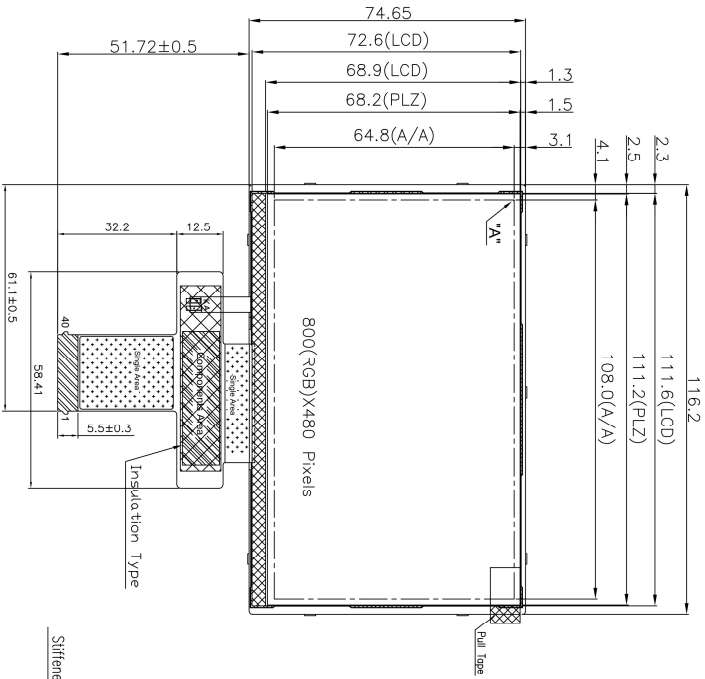

Specification:
 1. Display mode: 5.0" TFT (16.7M)/ Normally Black / Transmissive
 2. Viewing direction: Free
 3. Operating temperature: -30°C to +85°C
 Storage temperature: -30°C to +85°C
 4. Driver IC is: ST72568-G6-L or Compatible
 5. Backlight: 15 CHIP WHITE LED
 6. Unspecified tolerance: ±0.30mm
 7. ROHS compliant
 8. Luminous Intensity for LCM: 1000cd/m²(Tp)

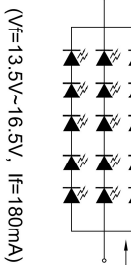
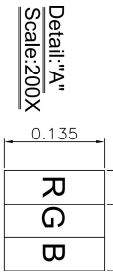
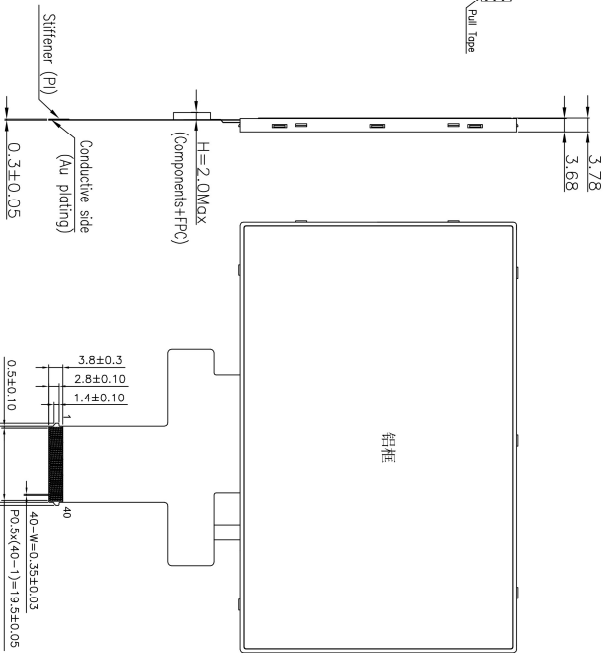

		MOD. Name	YB-TG800480S45A-N-A	DESIGNED	张雷	2025-03-09	Count Dwg.
		CHECKED	VERIFIED	APPROVED	FILE NAME		
UNIT	mm	SIZE	A4	SCALE	N-T-S		
Sheet		1					
Of		1					

1	K
2	A
3	GND
4	VDD
5	DISP
6	HSYNC
7	VSYNC
8	GND
9	DCLK
10	GND
11	DE
12	R0
13	R1
14	R2
15	R3
16	R4
17	R5
18	R6
19	R7
20	G0
21	G1
22	G2
23	G3
24	G4
25	G5
26	G6
27	G7
28	B0
29	B1
30	B2
31	B3
32	B4
33	B5
34	B6
35	B7
36	NC
37	NC
38	NC
39	NC
40	NC

6. Electrical Characteristics

6-1 Absolute Maximum Ratings

6-1-1 TFT Absolute Maximum Ratings

(Ta=25°C GND =0V)

Item	Symbol	Rating	Unit
Power Supply Voltage	VDD	- 0.3 ~ +4.0	V
IO Supply Voltage	VDDI	- 0.3 ~ +4.0	V
Charge Pump Supply Voltage	PVDD	- 0.3 ~ +4.0	V
Logic Input Voltage Range	VIN	-0.3 ~ VDDI + 0.3	V
Logic Output Voltage Range	VOUT	-0.3 ~ VDDI + 0.3	V
Operating Temperature Range	TOPR	-30 ~ +85	°C
Storage Temperature Range	TSTG	-40 ~ +125	°C

Note:

1. That the stress exceeds the Limiting Value listed above it may cause the driver IC permanent damage. These values are for stress only. IC should be operated under the DC/AC Characteristic conditions for normal operation. If these conditions are not met, IC operation may be error and the reliability may be deteriorated.

2. Parameters are valid over operating temperature range unless otherwise specified. All voltages are with respect to VSS unless otherwise noted.

3. Insure the voltage levels of VDDI, VDD, PVDD always matches the correct relation:

$$3.1V \leq VDDI \leq VDD = PVDD \leq 3.6V$$

4. VIN should be less than or equal to 3.6V. (VIN ≤ 3.6V)

5. Panel display quality depends on panel loading, and it may have the different performance at low/high temperature.

6. When the backlight LED is turned on which is the heat generation leads to the increasing temperature of the LCD module.

In order to protect the LCD driver IC against thermal effect, we advise that the position of backlight LED should not be close to the driver IC. The edge-lit type LED is recommended.

6-2 Operating Conditions

6-2-1 Recommended Operating Range

DC Electrical Characteristics (PVDD=VDD=VDDI= 3.3V, AGND= 0V, TA=25°C, Bare Chip)

Item	Symbol	Min.	Typ.	Max.	Unit	Conditions
IO Supply Voltage	VDDI	3.1	3.3	3.6	V	
Analog Supply Voltage	VDD	3.1	3.3	3.6	V	
Charge Pump Supply Voltage	PVDD	3.1	3.3	3.6	V	

6-2-2 DC Characteristics for Digital Circuit

DC Electrical Characteristics (PVDD=VDD=VDDI= 3.3V, AGND= 0V, TA=25°C, Bare Chip)

Item	Symbol	Min.	Typ.	Max.	Unit	Conditions
Logic-High Input Voltage	Vih	0.7VDDI	-	VDDI	V	
Logic-Low Input Voltage	Vil	DGND	-	0.3VDDI	V	
Logic-High Output Voltage	Voh	VDDI-0.4	-	VDDI	V	
Logic-Low Output Voltage	Vol	DGND	-	DGND+0.4	V	

6-2-3 DC Characteristics for Analog Circuit

DC Electrical Characteristics (PVDD=VDD=VDDI= 3.3V, AGND= 0V, TA=25°C, Bare Chip)

Item	Symbol	Min.	Typ.	Max.	Unit	Conditions
Positive High-Voltage Power	VGHS	9	15	17	V	No Load@ FR=60Hz
Negative High-Voltage Power	VGL	-11.5	-10.5	-7	V	
Output Voltage Deviation	Vod	-	±40	±50	mV	
Standby Current	Isc	-	-	50	uA	
Operation Current	Ioc	-	40	-	mA	

6-2-4 DC Characteristics for LVDS Receiver Circuit

Single End Signals

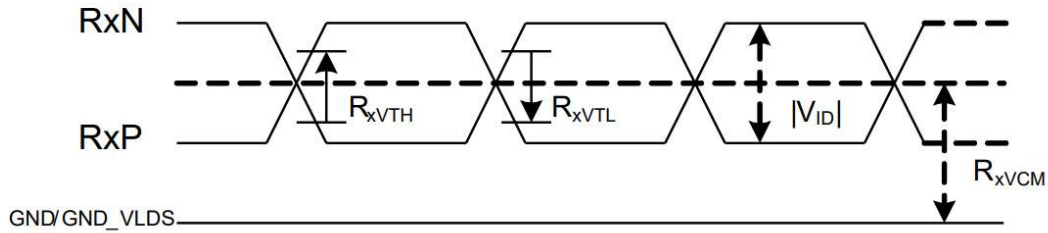

Differential Signals

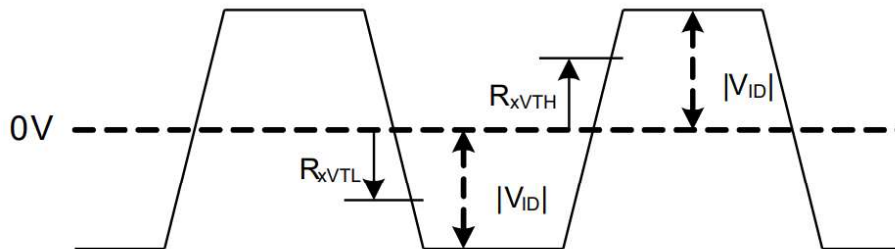

DC Electrical Characteristics (PVDD=VDD=VDDI= 3.3V, AGND= 0V, TA=25°C, Bare Chip)

Item	Symbol	Min.	Typ.	Max.	Unit	Conditions
Differential Input High Threshold Voltage	R _{xVTH}	-	-	0.1	V	R _{xVCM} = 1.2V
Differential Input Low Threshold Voltage	R _{xVTL}	-0.1	-	-	V	
Input Voltage Range (Singed-End)	R _{xVIN}	0	-	VDD-1.0	V	
Differential Input Common Mode Voltage	R _{xVCM}	V _{ID} /2	-	2.4- V _{ID} /2	V	
Differential Input Voltage	V _{ID}	0.2	-	0.6	V	
Differential Input Leakage Current	R _{VxIz}	-10	-	10	uA	
LVDS Digital Operating Current	I _{VDD_LVDS}	-	10	15	mA	
LVDS Digital Stand-by Current	I _{STBD_LVDS}	-	10	50	uA	
Differential Input Termination Resistance	R _{ID}	90	100	110	Ω	

Note: GND =0V

6-3 AC Characteristics

AC Electrical Characteristics (PVDD=VDD=VDDI= 3.3V, AGND= 0V, TA=25°C, Bare Chip)

6-3-1 System Operation AC Characteristics

DC Electrical Characteristics (PVDD=VDD=VDDI= 3.3V, AGND= 0V, TA=25°C, Bare Chip)

Item	Symbol	Min.	Typ.	Max.	Unit	Conditions
VDD Power Source Slew Time	TPOR	-	-	20	ms	From 0V to 99% VDD
GRB Pulse Width	tRSTW	10	50	-	us	R=10Kohm, C=1uF
SD Output Stable Time	Tst	-	-	12	us	Output settled within +20mV Loading = 6.8k+28.2pF.
GD Output Rise and Fall Time	Tgst	-	-	6	us	Output settled (5%~95%), Loading = 4.7k+29.8pF

6-3-2 System Bus Timing for 3-Wire SPI Interface

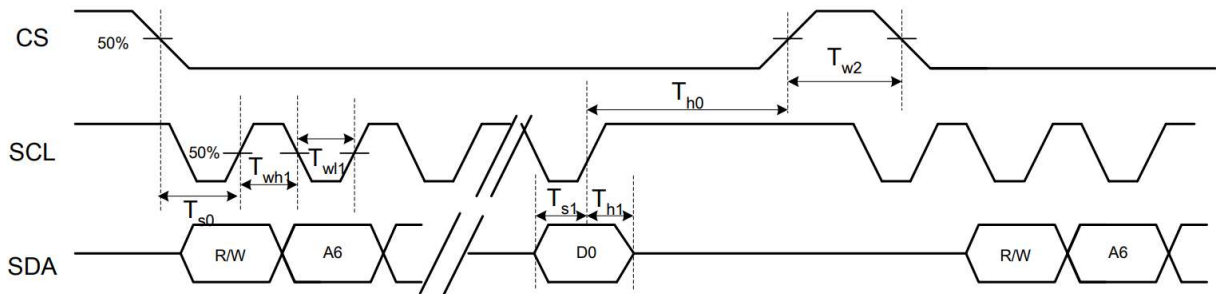

DC Electrical Characteristics (PVDD=VDD=VDDI= 3.3V, AGND= 0V, TA=25°C, Bare Chip)

Item	Symbol	Min.	Typ.	Max.	Unit	Conditions
CS Input Setup Time	T_{s0}	50	-	-	ns	
Serial Data Input Setup Time	T_{s1}	50	-	-	ns	
CS Input Hold Time	T_{h0}	50	-	-	ns	
Serial Data Input Hold Time	T_{h1}	50	-	-	ns	
SCL Write Pulse High Width	T_{wh1}	50	-	2000	ns	
SCL Write Pulse Low Width	T_{wl1}	50	-	2000	ns	
SCL Read Pulse High Width	T_{rh1}	300	-	2000	ns	
SCL Read Pulse Low Width	T_{rl1}	300	-	2000	ns	
CS Pulse High Width	T_{w2}	400	-	-	ns	

6-3-3 System Bus Timing for RGB Interface

DCLK Neagive Polarity (DCLKPOL="H")

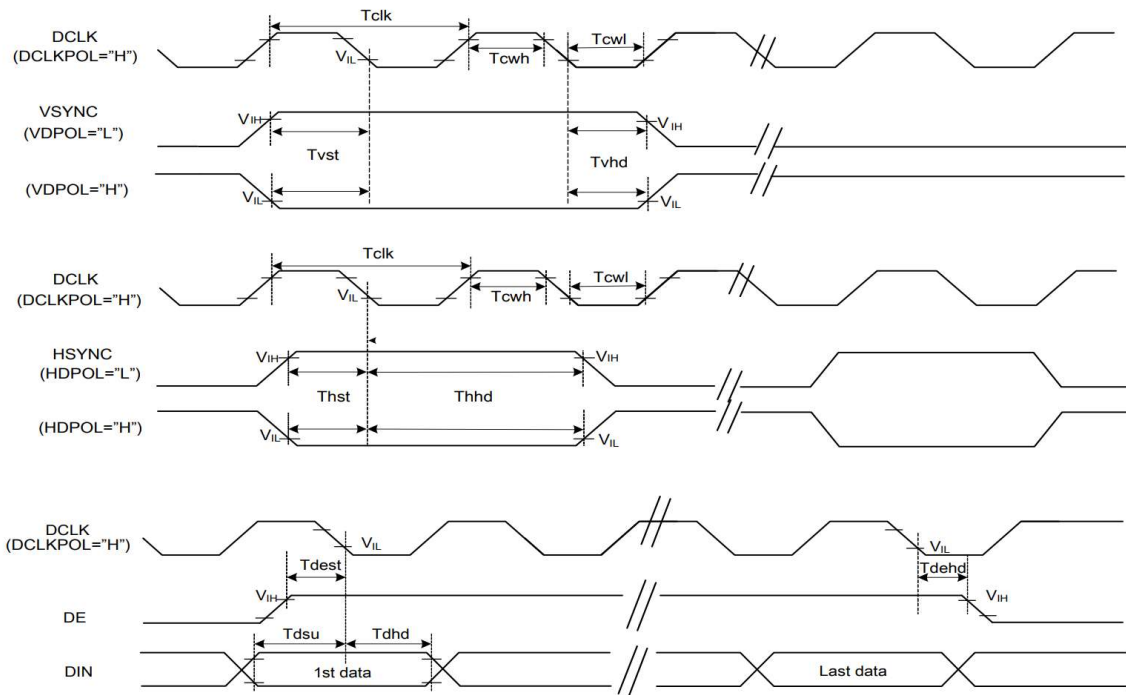

DCLK Positive Polarity (DCLKPOL="L")

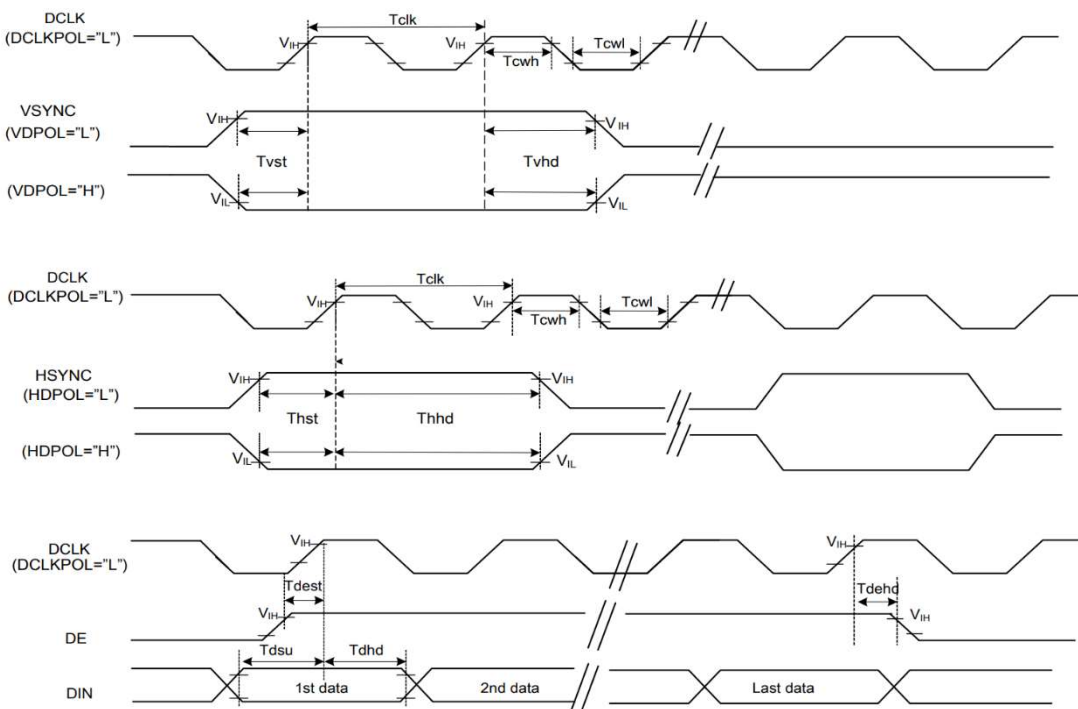

DC Electrical Characteristics (PVDD=VDD=VDDI= 3.3V, AGND= 0V, TA=25°C, Bare Chip)

Item	Symbol	Min.	Typ.	Max.	Unit	Conditions
CLK Pulse Duty	Tcw	40	50	60	%	
VSYNC Setup Time	Tvst	10	-	-	ns	
VSYNC Hold Time	Tvhd	10	-	-	ns	
HSYNC Setup Time	Thst	10	-	-	ns	
HSYNC Hold Time	Thhd	10	-	-	ns	
Data Setup Time	Tdsu	10	-	-	ns	
Data Hold Time	Tdhd	10	-	-	ns	
DE Setup Time	Tdest	10	-	-	ns	
DE Hold Time	Tdehd	10	-	-	ns	

6-3-4 Reset timing

Setting GRB pin to “L” (hardware reset) can initialize internal function. Initialized by GRB pin is essential before operating. There are two suggestions for hardware reset connection.

(1) The GRB pin with external RC circuit.

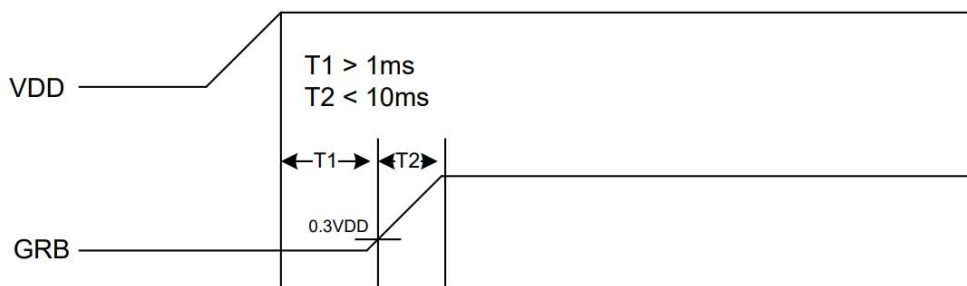
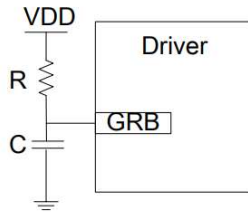

(2) The GRB pin controlled by MCU.

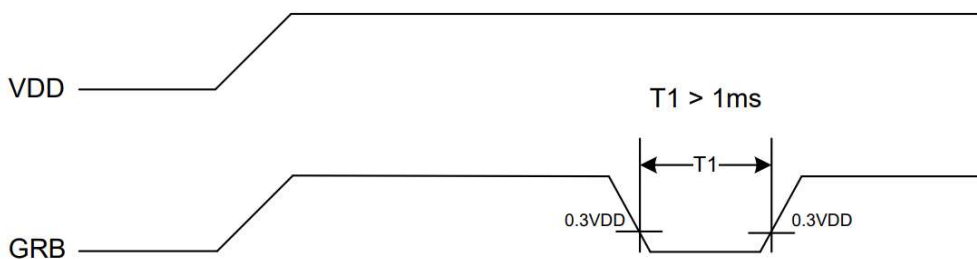
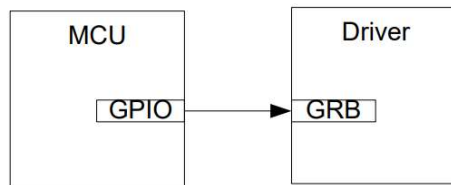

7. Optical Characteristics:

Item	Symbol	Conditions	Specifications			Unit	Note	
			Min	Typ	Max			
Transmittance	T (%)	-	-	4.63	-	-	-	
Contrast Ratio	CR	$\Theta=0$ Normal Viewing angle	-	1000	-		(1) (2)	
Response time	TR+TF	-	-	30	-	ms	(1) (3)	
Viewing angle	Hor.	Θ_{x+}	CR ≥ 10	-	80	-	deg.	-
		Θ_{x-}		-	80	-		
	Ver.	Θ_{y+}		-	80	-		
		Θ_{y-}		-	80	-		

Measuring Condition

1. Measuring surrounding: dark room
2. Ambient temperature: $25 \pm 2^{\circ}\text{C}$
3. 30 min. Warm-up time.

Color of CIE Coordinate:

Item		Symbol	Condition	Min.	Typ.	Max.
Chromaticity Coordinates (Transmissive)	Red	x	$\theta = \phi = 0^{\circ}$ LED Backlight	TBD	0.622	TBD
		y		TBD	0.362	TBD
	Green	x		TBD	0.320	TBD
		y		TBD	0.611	TBD
	Blue	x		TBD	0.150	TBD
		y		TBD	0.096	TBD
	White	x		TBD	0.293	TBD
		y		TBD	0.333	TBD

Note (1) Definition of Viewing Angle:

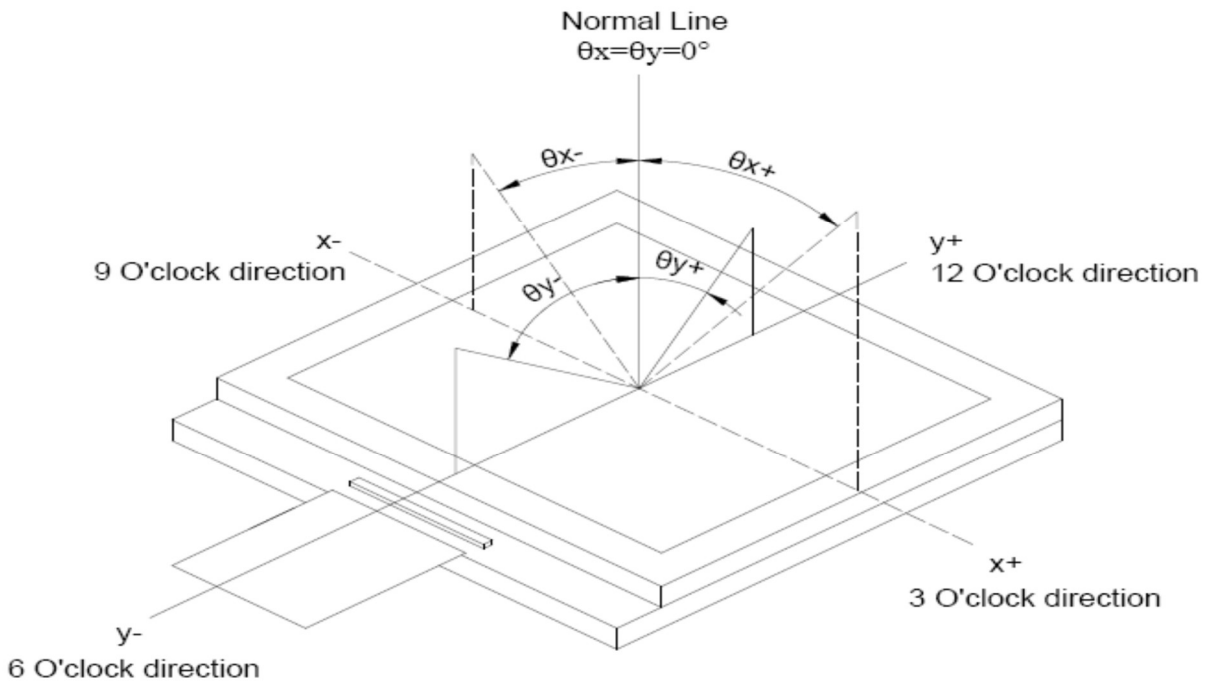

Note (2) Definition of Contrast Ratio (CR):
measured at the center point of panel

$$\text{Contrast ratio (CR)} = \frac{\text{Photo detector output when LCD is at "White" state}}{\text{Photo detector output when LCD is at "Black" state}}$$

Note (3) Definition of Response Time: Sum of TR and TF

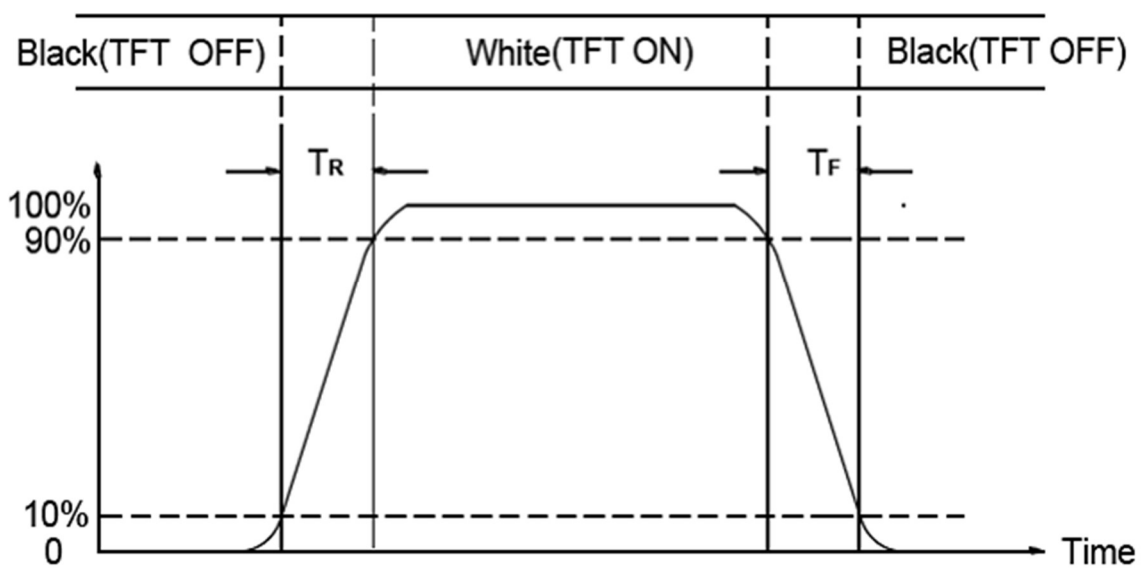

8. Interface Pin Assignment:

No.	Symbol	Function
1	K	Cathode of LED backlight
2	A	Anode of LED backlight
3	GND	Power ground
4	VDD	Power supply for analog circuit
5	DISP	Display on/off mode control. (a) DISP=L, standby mode. (b) DISP=H, normal display mode.
6	HSYNC	Horizontal sync signal applied to the RGB interface. HSYNC pin should be connected to “L” when it is used in LVDS interface.
7	VSYNC	Vertical sync signal applied to the RGB interface. VSYNC pin should be connected to “L” when it is used in LVDS interface.
8	GND	Power ground
9	DCLK	Data clock signal input
10	GND	Power ground
11	DE	Data input enable applied to the RGB interface. DE pin should be connected to “L” when it is used in LVDS interface.
12~19	R0~ R7	8 bit data bus display red data
20~27	G0~ G7	8 bit data bus display green data
28~35	B0~ B7	8 bit data bus display blue data
36~40	NC	No connection

9. Block Diagram:

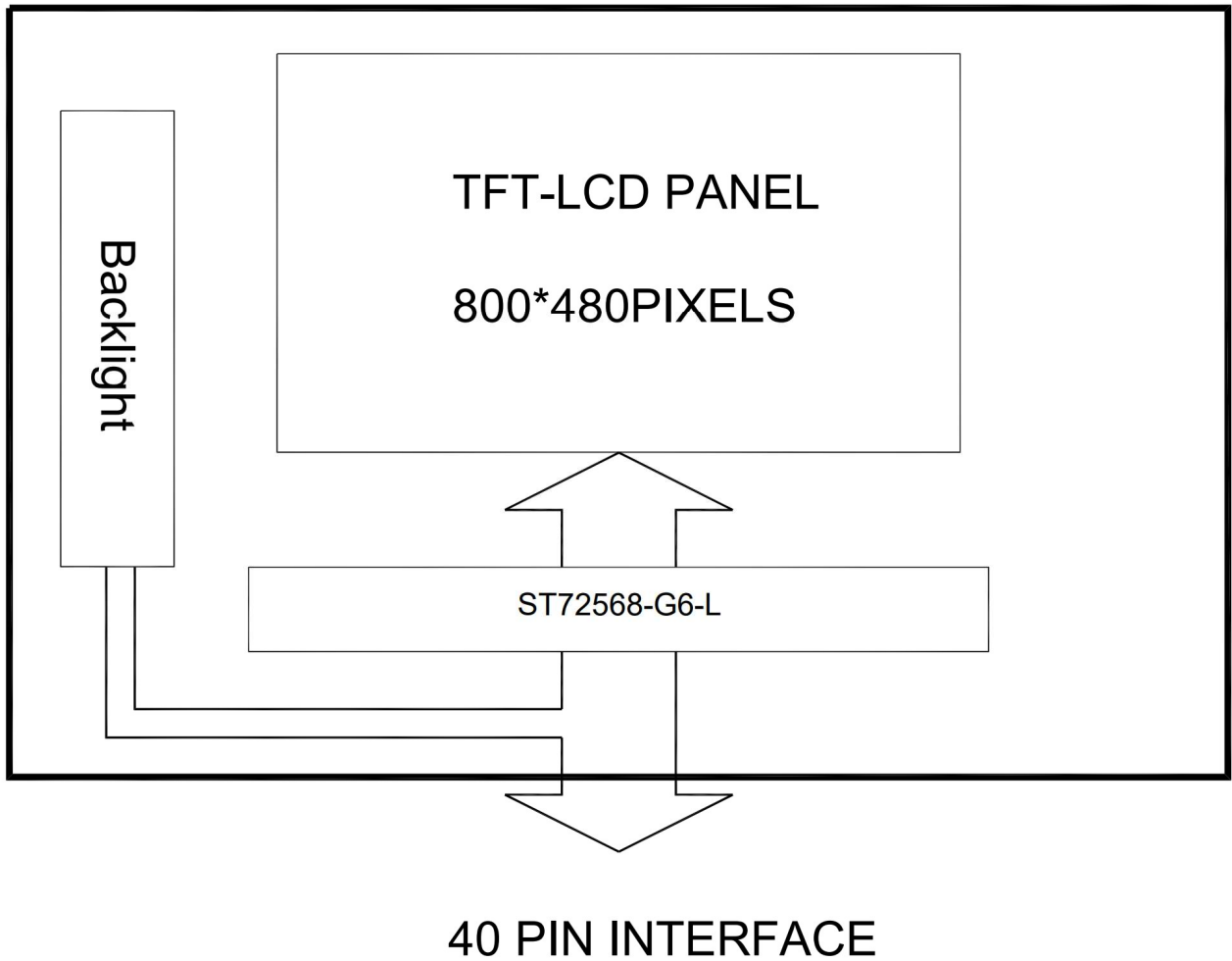

10. Backlight:

1. Standard Lamp Styles (Edge Lighting Type):
The LED chips are distributed over the edge light area of the illumination unit, which gives the less power consumption:
2. The Main Advantages of the LED Backlight are as following:
 - 2.1 The brightness of the backlight can simply be adjusted.
By a resistor or a potentiometer.

3. Data About LED Backlight:

($T_a=25^{\circ}\text{C}$)

PARAMETER	Sym.	Min.	Typ.	Max.	Unit	Test Condition	Note
Supply Current	I	-	180	-	mA	-	
Supply Voltage	V	13.5	15	16.5	V	If=180mA	
Luminous Intensity for LCM	IV	-	1000	-	cd/m ²		2
Uniformity for LCM	-	75	-	-	%		3
Life Time	-	20000	-	-	Hr.		4
Color	White						

NOTE:

1. Backlight Only
2. Average Luminous Intensity of P1-P5
3. Uniformity = Min/Max * 100%
4. LED life time defined as follows: The final brightness is at 50% of original brightness

Measured Method: (X*Y: Light Area)

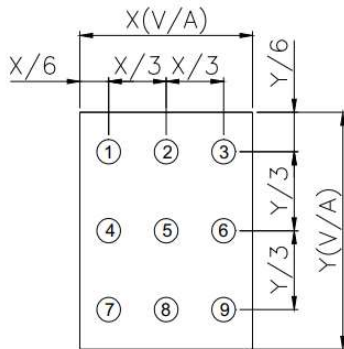

Internal Circuit Diagram

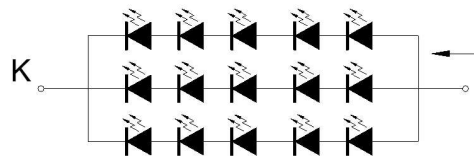

($V_f=13.5\text{V}\sim 16.5\text{V}$, $I_f=180\text{mA}$)

(Effective spatial Distribution)

Using aperture of 1° , distance 50cm.

11. Standard Specification for Reliability :

11-1. Standard Specifications for Reliability of LCD Module

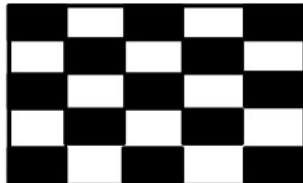
No	Item	Description
01	High temperature operation	The sample should be allowed to stand at 85°C for 120 hours under driving condition and then returning it to normal temperature condition, and allowing it stand for 2 hours.
02	Low temperature operation	The sample should be allowed to stand at -30°C for 120 hours under driving condition and then returning it to normal temperature condition, and allowing it stand for 2 hours.
03	High temperature storage	The sample should be allowed to stand at 85°C for 240 hours under no-load condition, and then returning it to normal temperature condition, and allowing it stand for 2 hours.
04	Low temperature storage	The sample should be allowed to stand at -30°C for 240 hours under no-load condition, then returning it to normal temperature condition, and allowing it stand for 2 hours.
05	Moisture storage	The sample should be allowed to stand at 60°C,90%RH MAX for 240 hours under no-load condition, then taking it out and drying it at normal temperature for 2 hours.
06	Thermal shock storage	The sample should be allowed to stand the following 10 cycles : -30°C for 30 minutes → normal temperature for 5 minutes → +80°C for 30 minutes → normal temperature for 5 minutes, as one cycle.
07	Packing vibration	Frequency range : 10Hz ~ 55Hz Amplitude of vibration : 1.5mm Sweep time: 12 min X,Y,Z 2 hours for each direction.
08	Packing drop test	According to ISTA 1A 2001.
09	Electrical Static Discharge	Air: ±4KV 150pF/330Ω 5 times
		Contact: ±2KV 150pF/330Ω 5 time
10	Imaging sticking	Burn in:5*5 Chess,1h@25°C. Inspection Pattern:50% grey, Perpendicular view, after 5 Min,the mura must disappear 

*Sample size for each test item is 3~5pcs

11 - 2. Testing Conditions and Inspection Criteria

For the final test the testing sample must be stored at room temperature for 24 hours, after the tests listed in Table 12.1, Standard specifications for Reliability have been executed in order to ensure stability.

No	Item	Test Model	In section Criteria
01	Current Consumption	Refer To Specification	The current consumption should conform to the product specification.
02	Contrast	Refer To Specification	After the tests have been executed, the contrast must be larger than half of its initial value prior to the tests.
03	Appearance	Visual inspection	Defect free.

11- 3. MTBF

MTBF	Functions, performance, appearance, etc. shall be free from remarkable deterioration within 50,000 hours under ordinary operating and storage conditions room temperature (25±5°C), normal humidity (50±10% RH), and in area not exposed to direct sun light.
------	---

12. Specification of Quality Assurance:

12-1. Purpose

This standard for Quality Assurance should affirm the quality of LCD module products to supply to purchaser by YEEBO CORPORATION (Supplier).

12-2. Standard for Quality Test

a. Inspection:

Before delivering, the supplier should take the following tests, and affirm the quality of product.

b. Electro-Optical Characteristics:

According to the individual specification to test the product.

c. Test of Appearance Characteristics:

According to the individual specification to test the product.

d. Test of Reliability Characteristics:

According to the definition of reliability on the specification for testing products.

e. Delivery Test:

Before delivering, the supplier should take the delivery test.

(i) Test method: According to **ISO2859-1**. General Inspection Level II take a single time.

(ii) The defects classify of AQL as following:

Major defect: AQL =0.65

Minor defect: AQL =2.5

Total defects: AQL =2.5

12-3. Non- conforming Analysis & Deal with Manners

a. Non- conforming Analysis:

(i) Purchaser should supply the detail data of non- conforming sample and the non-conforming.

(ii) After accepting the detail data from purchaser, the analysis of non- conforming should be finished in two weeks.

(iii) If supplier can not finish analysis on time, must announce purchaser before 3 days.

b. Disposition of non- conforming:

(i) If find any product defect of supplier during assembly time, supplier must change the good product for every defect after recognition.

(ii) Both supplier and customer should analyze the reason and discuss the disposition of non- conforming when the reason of nonconforming is not sure.

12-4. Agreement items

Both sides should discuss together when the following problems happen.

a. There is any problem of standard of quality assurance, and both sides should think that must be modified.

b. There is any argument item which does not record in the standard of quality assurance.

c. Any other special problem.

12-5. Standard of the Product Appearance Test

a. Manner of appearance test:

(i) Illumination: External Appearance Inspection : 1000±200 Lux ; Light on inspection : 200±50 Lux.

(ii) To be a distance about 30±5 cm in front of LCD unit, viewing line should be perpendicular to the surface of the module judge the visual appearance with human's eyes.

(iii) Scope of inspection perspective:

The inspection angle of IPS screen is within ±30° of the vertical line on the product surface; The TN screen inspection angle is -15° from the vertical line of the product surface in the 12 o'clock direction to 30° from the vertical line of the product surface in the 6 o'clock direction.

(iii) Temperature: 25±5°C Humidity: 60±10%RH

IPS:

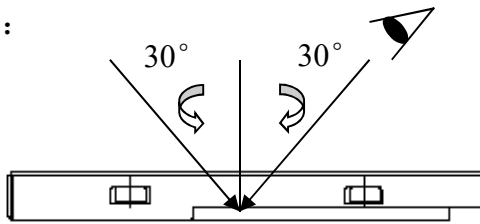

TN:

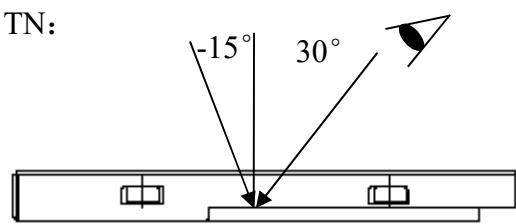

(iv) Definition of area:

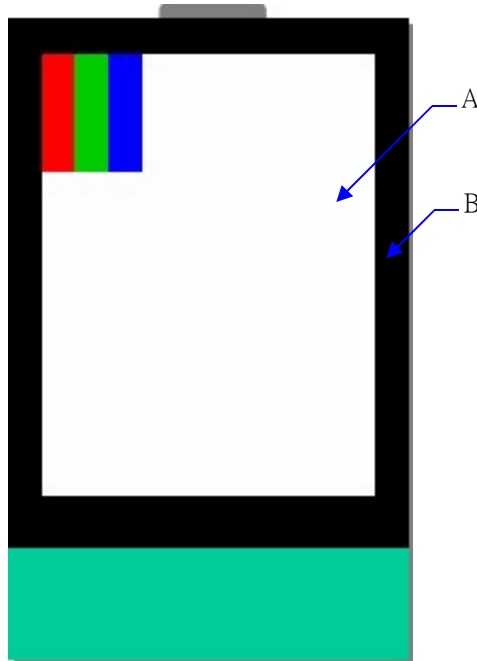

A. Area: Viewing area.

B. Area: Out of viewing area.

(Outside viewing area)

b. Basic principle:

(i) It will accord to the AQL when the standard cannot be described.

(ii) The sample of the lowest acceptable quality level must be discussed by both supplier and customer when any dispute happened.

(iii) Must add new item on time when it is necessary.

c. Standard of inspection: (Unit: mm)

12-6. Inspection specification

Defect out of viewing area can be neglected.

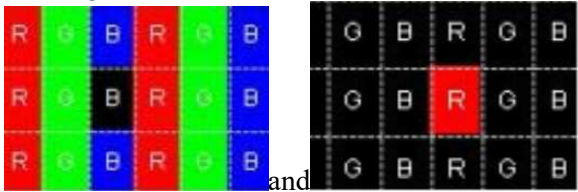
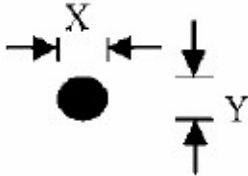
NO	Item	Criterion	AQL														
01	Electrical Testing	1.1 Missing vertical, horizontal segment, segment contrast defect. 1.2 Missing character, dot or icon. 1.3 Display malfunction. 1.4 No function or no display. 1.5 Current consumption exceeds product specifications. 1.6 LCD viewing angle defect. 1.7 Mixed product types.	0.65														
02	Pixel Defect	2.1 Bright and Black dot define:  and Pixel Defect as below drawing: <table border="1" data-bbox="418 969 1086 1245"> <thead> <tr> <th>Type</th> <th>Acceptable Q'ty</th> </tr> </thead> <tbody> <tr> <td>Bright Dot</td> <td>$N \leq 1$</td> </tr> <tr> <td>Two bright dots</td> <td>$N \leq 0$</td> </tr> <tr> <td>Dark Dot</td> <td>$N \leq 3$</td> </tr> <tr> <td>Two Dark dots</td> <td>$N \leq 1$</td> </tr> <tr> <td>Three Dark dots</td> <td>$N \leq 0$</td> </tr> <tr> <td>Total(Bright+Dark dot)</td> <td>$N \leq 3$</td> </tr> </tbody> </table> *Densely spaced: No more than two spots within 10mm.	Type	Acceptable Q'ty	Bright Dot	$N \leq 1$	Two bright dots	$N \leq 0$	Dark Dot	$N \leq 3$	Two Dark dots	$N \leq 1$	Three Dark dots	$N \leq 0$	Total(Bright+Dark dot)	$N \leq 3$	2.5
Type	Acceptable Q'ty																
Bright Dot	$N \leq 1$																
Two bright dots	$N \leq 0$																
Dark Dot	$N \leq 3$																
Two Dark dots	$N \leq 1$																
Three Dark dots	$N \leq 0$																
Total(Bright+Dark dot)	$N \leq 3$																
03	LCD , Touch Panel and Backlight Black and white spots/lines contamination (Foreign Material)	3.1 Dot type: As following drawing $\Phi = (X+Y) / 2$  <table border="1" data-bbox="860 1413 1394 1565"> <thead> <tr> <th>Size(mm)</th> <th>Acceptable Q'ty</th> </tr> </thead> <tbody> <tr> <td>$\Phi \leq 0.10$</td> <td>Accept no dense</td> </tr> <tr> <td>$0.10 < \Phi \leq 0.30$</td> <td>3</td> </tr> <tr> <td>$0.30 < \Phi$</td> <td>0</td> </tr> </tbody> </table> 3.1.1 Not visible through 5% ND filter 3.1.2 Densely spaced: No more than two spots within 5mm. 3.1.3 This is acceptable when surface dirt can be removed by wiping.	Size(mm)	Acceptable Q'ty	$\Phi \leq 0.10$	Accept no dense	$0.10 < \Phi \leq 0.30$	3	$0.30 < \Phi$	0	2.5						
Size(mm)	Acceptable Q'ty																
$\Phi \leq 0.10$	Accept no dense																
$0.10 < \Phi \leq 0.30$	3																
$0.30 < \Phi$	0																
		3.2 Tiny bright dot、Dense tiny highlights: Definition of Tiny bright dot: $\Phi < 0.10\text{mm}$; Ignore, clustered is not allowed($N \leq 5, D \leq 5$) *Not visible through 5% ND filter	2.5														

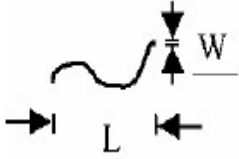
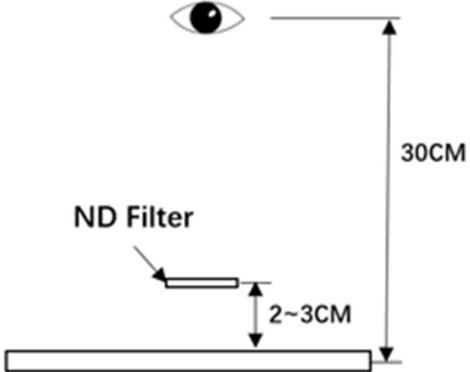
NO	Item	Criterion	AQL												
03	LCD , Touch Panel and Backlight Black and white spots/lines contaminati on (Foreign Material)	3.3 Line type: (As following drawing)  <table border="1" data-bbox="774 291 1348 504"> <thead> <tr> <th>Length(mm)</th> <th>Width(mm)</th> <th>Acceptable Q'ty</th> </tr> </thead> <tbody> <tr> <td>---</td> <td>$W \leq 0.03$</td> <td>Accept no dense</td> </tr> <tr> <td>$L \leq 5.0$</td> <td>$0.03 < W \leq 0.075$</td> <td>3</td> </tr> <tr> <td>---</td> <td>$0.075 < W$</td> <td>Rejection</td> </tr> </tbody> </table> * Densely spaced: No more than two spots within 5mm.	Length(mm)	Width(mm)	Acceptable Q'ty	---	$W \leq 0.03$	Accept no dense	$L \leq 5.0$	$0.03 < W \leq 0.075$	3	---	$0.075 < W$	Rejection	2.5
Length(mm)	Width(mm)	Acceptable Q'ty													
---	$W \leq 0.03$	Accept no dense													
$L \leq 5.0$	$0.03 < W \leq 0.075$	3													
---	$0.075 < W$	Rejection													
04	Polarizer bubbles	If bubbles are visible, Judge using black spot specifications, not easy to find, must check in specify direction. <table border="1" data-bbox="758 739 1348 907"> <thead> <tr> <th>Size Φ(mm)</th> <th>Acceptable Q'ty</th> <th>Area</th> </tr> </thead> <tbody> <tr> <td>$\Phi \leq 0.20$</td> <td>Accept no dense</td> <td>V.A</td> </tr> <tr> <td>$0.20 < \Phi \leq 1.00$</td> <td>3</td> <td>V.A</td> </tr> <tr> <td>$1.00 < \Phi$</td> <td>0</td> <td>V.A</td> </tr> </tbody> </table> * Densely spaced: No more than two spots within 5mm. * Outside of the V.A. is disregard.	Size Φ (mm)	Acceptable Q'ty	Area	$\Phi \leq 0.20$	Accept no dense	V.A	$0.20 < \Phi \leq 1.00$	3	V.A	$1.00 < \Phi$	0	V.A	2.5
Size Φ (mm)	Acceptable Q'ty	Area													
$\Phi \leq 0.20$	Accept no dense	V.A													
$0.20 < \Phi \leq 1.00$	3	V.A													
$1.00 < \Phi$	0	V.A													
05	Mura	Not visible through 5% ND filter. *ND card is 2~3cm from the panel, human eye is 30±5cm from the panel; The line of sight is moved to the ND card for judgment: if it is not visible for 2-3 seconds - OK, visible – NG 	2.5												

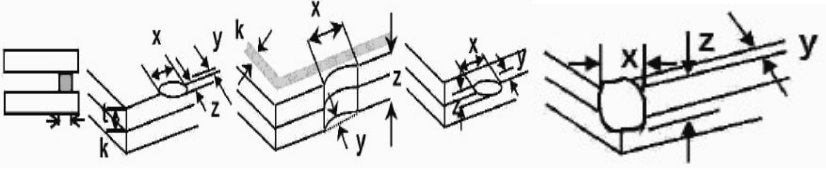
06	Chipped glass	<p>Symbols: x: Chip length y: Chip width z: Chip thickness k: Seal width t: Single-layer glass thickness a: LCD side length L: Electrode pad length</p> <p>Chip on panel surface and crack between panels and Corner crack:</p>  <table border="1" data-bbox="379 510 1198 622"> <tr> <td>z: Chip thickness</td> <td>y: Chip width</td> <td>x: Chip length</td> </tr> <tr> <td>$z \leq t$</td> <td>Not over BM glue area</td> <td>$x \leq 1/8a$</td> </tr> </table> <p>⊙ Unit: mm ⊙ If there are 2 or more chips, x is the total length of each chip. ⊙ If there chipped area touches the ITO terminal, over 2/3 of the ITO must remain and do not affect the function.</p>	z: Chip thickness	y: Chip width	x: Chip length	$z \leq t$	Not over BM glue area	$x \leq 1/8a$	2.5
z: Chip thickness	y: Chip width	x: Chip length							
$z \leq t$	Not over BM glue area	$x \leq 1/8a$							
NO	Item	Criterion	AQL						
07	Scratches	Follow NO.3 -3 Line Type.	2.5						
08	Cracked glass	The LCD with extensive crack is not acceptable.	2.5						
09	Backlight elements	9.1 Illumination source flickers when lit. 9.2 Spots or scratches that appear when lit must be judged. Using LCD spot, lines and contamination standards. 9.3 Backlight doesn't light or color is wrong.	2.5 2.5 0.65						
10	Bezel	Bezel must comply with product specifications.	2.5						

11	PCB、COB	11.1 COB seal may not have pinholes larger than 0.2mm or contamination.	2.5
		11.2 COB seal surface may not have pinholes through to the IC.	2.5
		11.3 The height of the COB should not exceed the height indicated in the assembly diagram.	2.5
		11.4 There may not be more than 2mm of sealant outside the seal area on PCB. And there should be no more than three places.	2.5
		11.5 Parts on PCB must be the same as on the production characteristic chart, There should be no wrong parts, missing parts or excess parts.	0.65
		11.6 The jumper on the PCB should conform to the product characteristic chart.	0.65
		11.7 PCBA cosmetic control base on latest IPC standard, IPC-A-610, acceptable limit of grade 2.	2.5
12	FPC	Affect function rejection, do not affect function acceptance.	2.5
13	Soldering	13.1 No cold solder joints, missing solder connections, oxidation or icicle.	2.5
		13.2 No short circuits in components on PCB or FPC.	0.65

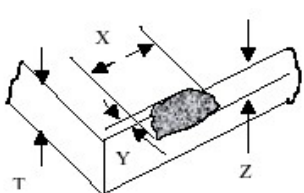
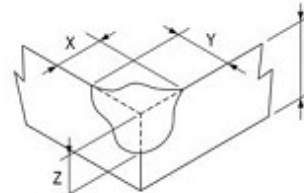
NO	Item	Criterion	AQL					
14	Touch Panel Chipped glass	Edge breakage can't affect visual effect (edge breakage can't cause damage to circuit); over lens have no visual damage	2.5					
		 						
		<table border="1"> <thead> <tr> <th>x: Chip length</th> <th>y: Chip width</th> <th>z: Chip thickness</th> <th>Acceptable numbers</th> </tr> </thead> <tbody> <tr> <td>$x \leq 2\text{mm}$</td> <td>$y \leq 1.5\text{mm}$</td> <td>$z \leq T$</td> <td>2</td> </tr> </tbody> </table>		x: Chip length	y: Chip width	z: Chip thickness	Acceptable numbers	$x \leq 2\text{mm}$
x: Chip length	y: Chip width	z: Chip thickness	Acceptable numbers					
$x \leq 2\text{mm}$	$y \leq 1.5\text{mm}$	$z \leq T$	2					

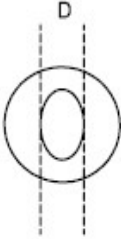
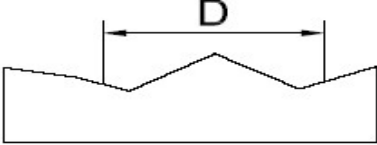
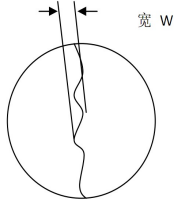

15	Touch Panel(Fish eye、dent and bubble on film)	<table border="1"> <tr> <th>SIZE(mm)</th> <th>Acceptable Q'ty</th> </tr> <tr> <td>$\Phi \leq 0.2$</td> <td>Accept no dense</td> </tr> <tr> <td>$0.2 < D \leq 0.50$</td> <td>3</td> </tr> <tr> <td>$0.50 < D$</td> <td>0</td> </tr> </table>	SIZE(mm)	Acceptable Q'ty	$\Phi \leq 0.2$	Accept no dense	$0.2 < D \leq 0.50$	3	$0.50 < D$	0		2.5
		SIZE(mm)	Acceptable Q'ty									
$\Phi \leq 0.2$	Accept no dense											
$0.2 < D \leq 0.50$	3											
$0.50 < D$	0											
												
16	Touch Panel Newton ring	Newton ring dimension $\leq 1/2$ touch panel area and not affect font and line distortion ($\leq 2.5\%$), it is acceptable.		2.5								
17	Touch Panel Linearity	Less than 2.5% is acceptable.		2.5								
18	LCD Ripple	Touch the touch panel, cannot see the LCD ripple. Pen: R 1.0mm silicon rubber. Operation Force: 80g		2.5								
19	V/A printed edges sawtooth inspected according to this standard LOGO's sawtooth	Some contentious defect judged according to samples.		2.5								
		<table border="1"> <thead> <tr> <th>Product type</th> <th>Conditions</th> </tr> </thead> <tbody> <tr> <td>Same size</td> <td>1、width below 0.2mm (included) ignored, above 0.2mm NG 2、 Length not accounted</td> </tr> </tbody> </table>			Product type	Conditions	Same size	1、width below 0.2mm (included) ignored, above 0.2mm NG 2、 Length not accounted				
Product type	Conditions											
Same size	1、width below 0.2mm (included) ignored, above 0.2mm NG 2、 Length not accounted											
19	General appearance	19.1 Product packaging must the same as specified on packaging specification sheet.		0.65								
		19.2 Product dimension and structure must conform to product Specification sheet.		0.65								

13. Handling Precaution:

13-1 Handling of LCM

- Don't give external shock.
- Don't apply excessive force on the surface.
- Liquid in LCD is hazardous substance. Must not lick and swallow. When the liquid is attach to your hand, skin, cloth etc. Wash it out thoroughly and immediately.
- Don't operate it above the absolute maximum rating.
- Don't disassemble the LCM.
- The operators should be grounded whenever he/she comes into contact with the module. Never touch any of the conductive parts such as the LSI pads, the copper leads on the PCB and the interface terminals with any parts of the human body.
- The modules should be kept in antistatic bags or other containers resistant to static for storage.
- The module is coated with a film to protect the display surface. Be care when peeling off this protective film since static electricity may be generated.

13-2 Storage

- Store in an ambient temperature of $25\pm 10^{\circ}\text{C}$, and in a relative humidity of $50\pm 10\%\text{RH}$. Don't expose to sunlight or fluorescent light.
- Storage in a clean environment, free from dust, active gas, and solvent.
- Store in anti-static electricity container.
- Store without any physical load.

13-3 Soldering

- Use only soldering irons with proper grounding and no leakage.
- Iron: No higher than $310\pm 10^{\circ}\text{C}$ and less than 3 sec during Hand soldering.
- Rewiring: no more than 2 times.

14. Warranty

This product has been manufactured to specifications as a part for use in your company's general electronic products. It is guaranteed to perform according to delivery specifications. For any other use apart from general electronic equipment, we will not take responsibility if the product is used in medical devices, nuclear power control equipment, aerospace equipment, fire and security systems, or any other applications in which there is a direct risk to human life and where extremely high levels of reliability are required. If the product is to be used in any of the above applications, we will need to enter into a separate product liability agreement.

1. We cannot accept responsibility for any defect arise after additional process of the product (Including disassembly and reassembly), after product delivery.
2. We cannot accept responsibility for any defect, which may arise after the application of strong External force to the product.
3. We cannot accept responsibility for any defect, which may arise due to the application of static Electricity after the product has passed your company's acceptance inspection procedures.
4. We cannot accept responsibility for industrial property, which may arise through the use of your product, with exception to those issues relating directly to the structure or method of manufacturing of our product within one year from YEEBO shipment.
5. For Heatseal Product which required to heatseal by customer side, parts must be used within three months after delivery from factory.
6. For TAB Product which required to solder by customer side, parts must be used within three Months after delivery from factory.
7. The liability of YB is limited to repair or replacement on the terms set forth below. YB will not be responsible for any subsequent or consequential events or injury or damage to any personnel or user including third party personnel and/or user. Unless otherwise agreed in writing between YB and the customer, YB will only replace or repair any of its LCD which is found defective electrically or visually when inspected in accordance with YB GENERAL LCD INSPECTION STANDARD.

15. Guarantee:

Our products meet requirements of the environment.
YEEBO ROHS requirement is based on European Union Directive (ROHS) Requirements and Update.